

- EMC shielded 19" enclosure with handles.
- Detachable front/rear panels and Captive screws allow for easy maintenance as there is little risk of the screws dropping out and getting lost.
- A large selection of 21 different sizes in 2 different colors to choose from.
- Suitable for use as audio/visual equipment, communication equipment, rack mount computers, measuring instruments and others.

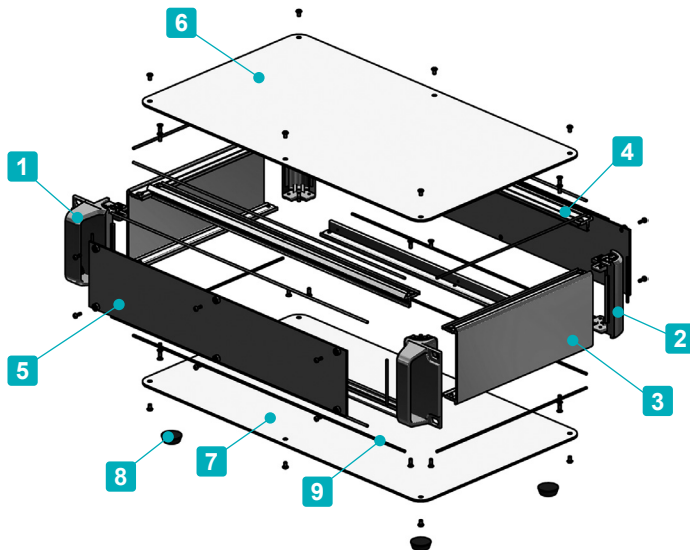

Included screws

- Top / Bottom cover
M3-5 original trapezoid head & Nickel plated x 8~16 pcs
- Frame
M3-8 flat head & Nickel plated x 16 pcs

Recommended torque : $\begin{cases} M2.5 : 0.15 \sim 0.2N \cdot m \\ M3 / M4 : 0.3 \sim 0.6N \cdot m \end{cases}$

* Recommended torque listed is for reference only; actual may differ. Assemble after testing torque.

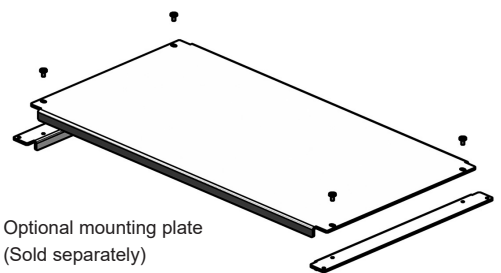

Components

No.	Part name	Pcs	Material	Color / Finish
1	Handle corner block	2	Diecast aluminium ADC12	Silver • Black / Painted (Unfinished inside)
2	Corner block	2	Diecast aluminium ADC12	Silver • Black / Painted (Unfinished inside)
3	Frame	2	Extruded aluminium A6063S-T5	Silver / Painted (Unfinished inside)
4	Panel support frame	4	Extruded aluminium A6063S-T5	Silver / Painted (Unfinished inside)
5	Panel	2	Aluminium A1100P	Silver / Painted (Conductive inside)
6	Top cover	1	Aluminium A1100P	Silver / Painted (Conductive inside)
7	Bottom cover	1	Aluminium A1100P	Silver / Painted (Conductive inside)
8	Rubber feet	4	Synthetic rubber	Black
9	EMC shielding gasket	16	Conductive fiber UL94V-0	Metallic gray

To select Screw and Color, follow steps **1** ~ **2** below to determine product number.

1 Screw

P Plus (Silver / Nickel plated)



H Hex (Silver / Nickel plated)

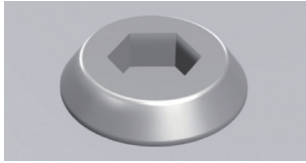

Hex wrench included.

2 Color

Please choose from the color combinations listed below.

S S



S B

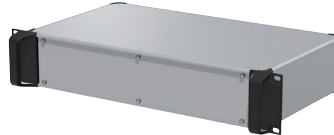

Product Number

To determine a product number, fill H-W-D dimensions and select Screw and Color code in the following blank boxes.

AUPRE



H-W-D dimensions

See below for dimensions / product no.



Screw

(P or H)



Color

(SS • SB)

Numbering example : If looking at "H88 x W430 x D250mm, Screw type H, Color type SB"

➔ **AUPRE 88-43-25 H-SB**

Product no. / Details ■ Please suffix screw and color code at the end of the product number.

Product no.	H	W	D	Weight (kg)
AUPRE 88-43-16□-□□	88	430	160	2.1
AUPRE 88-43-20□-□□	88	430	200	2.3
AUPRE 88-43-25□-□□	88	430	250	2.6
AUPRE 88-43-30□-□□	88	430	300	2.9
AUPRE 88-43-36□-□□	88	430	360	3.3
AUPRE 88-43-43□-□□	88	430	430	3.7
AUPRE 88-43-50□-□□	88	430	500	4.2
AUPRE133-43-16□-□□	132.5	430	160	2.5
AUPRE133-43-20□-□□	132.5	430	200	2.8
AUPRE133-43-25□-□□	132.5	430	250	3.1
AUPRE133-43-30□-□□	132.5	430	300	3.5
AUPRE133-43-36□-□□	132.5	430	360	3.9
AUPRE133-43-43□-□□	132.5	430	430	4.4
AUPRE133-43-50□-□□	132.5	430	500	4.9
AUPRE177-43-16□-□□	177	430	160	2.8
AUPRE177-43-20□-□□	177	430	200	3.1
AUPRE177-43-25□-□□	177	430	250	3.5
AUPRE177-43-30□-□□	177	430	300	3.9
AUPRE177-43-36□-□□	177	430	360	4.4
AUPRE177-43-43□-□□	177	430	430	5.0
AUPRE177-43-50□-□□	177	430	500	5.5

AUPRE dimensions

■ DXF/DWG/PDF/STP drawings available on our website.

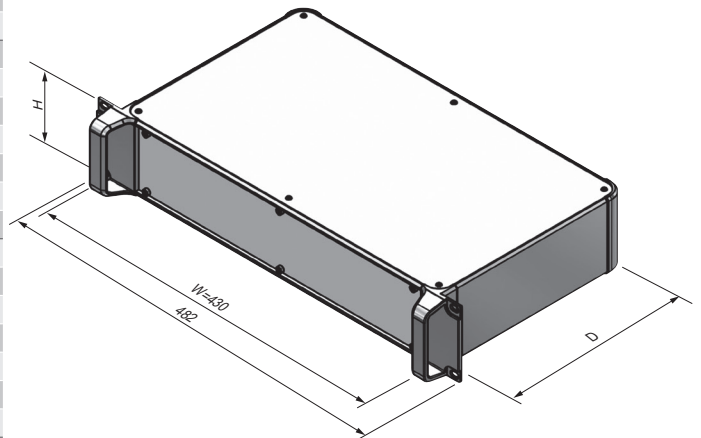

Accessories (Optional parts)

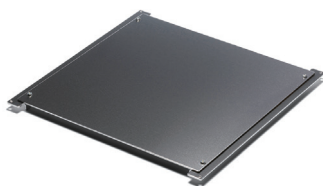

Mounting plate AUC series
See page 179 ~ 180



Rack mounting screw RT series
See page RT • RZ • RW



Rack mounting screw RZ series
See page RT • RZ • RW



Conductive

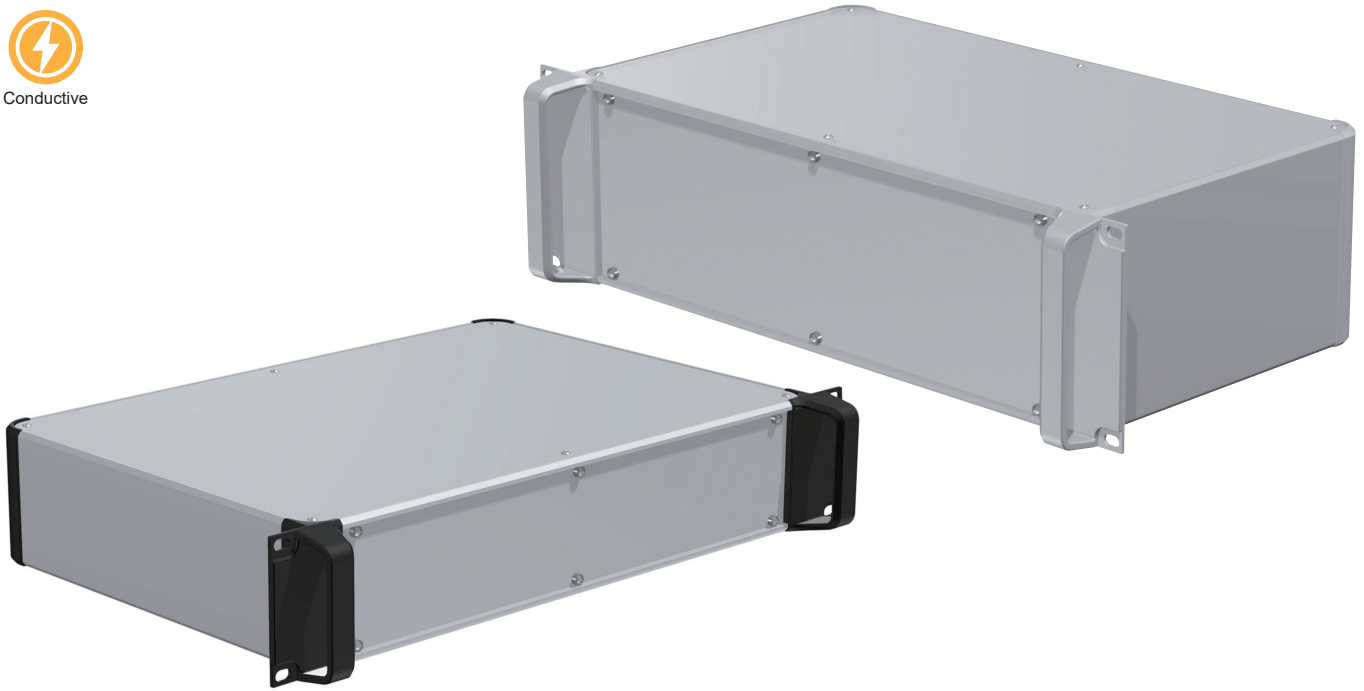

- 19" rack mount enclosure with detachable panels.
- The inner surface is unfinished, allowing the enclosure to be conductive.
- A large selection of 21 different sizes in 2 different colors to choose from.
- Suitable for use as audio/visual equipment, communication equipment, rack mount computers, measuring instruments and others.

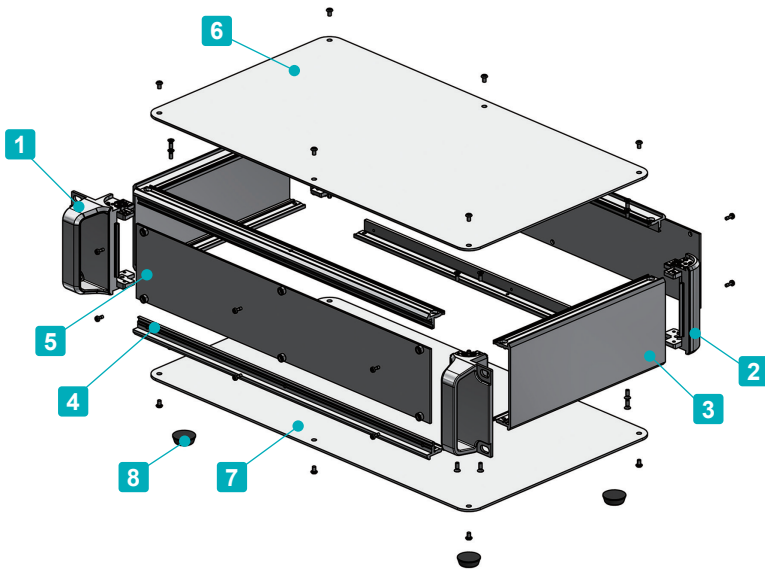

Included screws

- Top / Bottom cover
M3-5 original trapezoid head & Nickel plated x 8~16 pcs
- Frame
M3-8 flat head & Nickel plated x 16 pcs
- Panel
M2.5-7 pan head & Nickel plated x 12 pcs

Recommended torque : $\begin{cases} \text{M2.5 : } 0.15 \sim 0.2\text{N} \cdot \text{m} \\ \text{M3 : } 0.3 \sim 0.6\text{N} \cdot \text{m} \end{cases}$

* Recommended torque listed is for reference only; actual may differ. Assemble after testing torque.

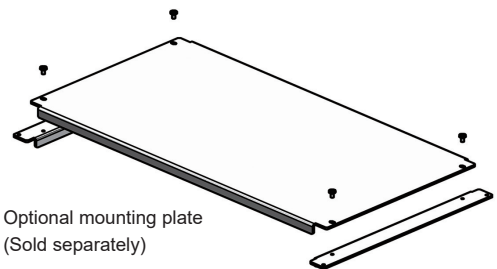

Components

No.	Part name	Pcs	Material	Color / Finish
1	Handle corner block	2	Diecast aluminium ADC12	Silver • Black / Painted (Unfinished inside)
2	Corner block	2	Diecast aluminium ADC12	Silver • Black / Painted (Unfinished inside)
3	Frame	2	Extruded aluminium A6063S-T5	Silver / Painted (Unfinished inside)
4	Panel support frame	4	Extruded aluminium A6063S-T5	Silver / Painted (Unfinished inside)
5	Panel	2	Aluminium A1100P	Silver / Painted (Conductive inside)
6	Top cover	1	Aluminium A1100P	Silver / Painted (Conductive inside)
7	Bottom cover	1	Aluminium A1100P	Silver / Painted (Conductive inside)
8	Rubber feet	4	Synthetic rubber	Black

To select Screw and Color, follow steps **1** ~ **2** below to determine product number.

1 Screw

P Plus (Silver / Nickel plated)



H Hex (Silver / Nickel plated)

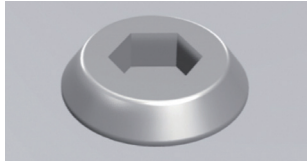

Hex wrench included.

2 Color

Please choose from the color combinations listed below.

S S



S B



Product Number

To determine a product number, fill H-W-D dimensions and select Screw and Color code in the following blank boxes.

AUPR



H-W-D dimensions

See below for dimensions / product no.



Screw
(P or H)



Color
(SS • SB)

Numbering example : If looking at "H88 x W430 x D250mm, Screw type H, Color type SB"

➔ **AUPR 88-43-25 H-SB**

Product no. / Details ■ Please suffix screw and color code at the end of the product number.

Product no.	H	W	D	Weight (kg)
AUPR 88-43-16□-□□	88	430	160	2.1
AUPR 88-43-20□-□□	88	430	200	2.3
AUPR 88-43-25□-□□	88	430	250	2.6
AUPR 88-43-30□-□□	88	430	300	2.9
AUPR 88-43-36□-□□	88	430	360	3.3
AUPR 88-43-43□-□□	88	430	430	3.7
AUPR 88-43-50□-□□	88	430	500	4.2
AUPR133-43-16□-□□	132.5	430	160	2.5
AUPR133-43-20□-□□	132.5	430	200	2.7
AUPR133-43-25□-□□	132.5	430	250	3.1
AUPR133-43-30□-□□	132.5	430	300	3.5
AUPR133-43-36□-□□	132.5	430	360	3.9
AUPR133-43-43□-□□	132.5	430	430	4.4
AUPR133-43-50□-□□	132.5	430	500	4.9
AUPR177-43-16□-□□	177	430	160	2.8
AUPR177-43-20□-□□	177	430	200	3.1
AUPR177-43-25□-□□	177	430	250	3.5
AUPR177-43-30□-□□	177	430	300	3.9
AUPR177-43-36□-□□	177	430	360	4.4
AUPR177-43-43□-□□	177	430	430	5.0
AUPR177-43-50□-□□	177	430	500	5.5

AUPR dimensions

■ DXF/DWG/PDF/STP drawings available on our website.

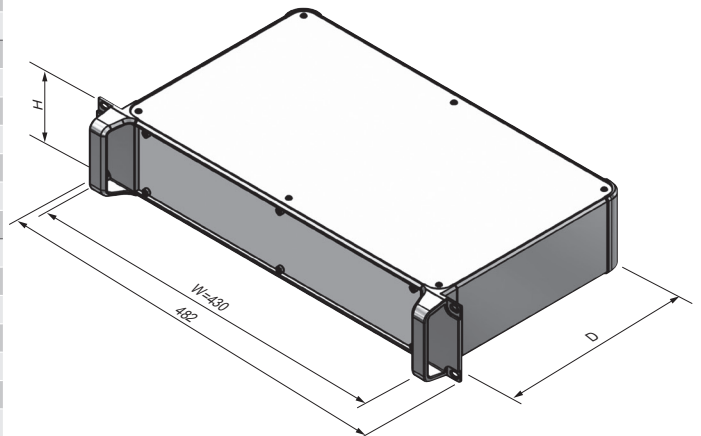

Accessories (Optional parts)

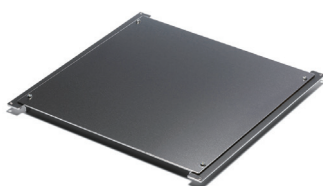

Mounting plate AUC series
See page 179 ~ 180



Rack mounting screw RT series
See page RT • RZ • RW



Rack mounting screw RZ series
See page RT • RZ • RW



EMC
Shielding
Effects

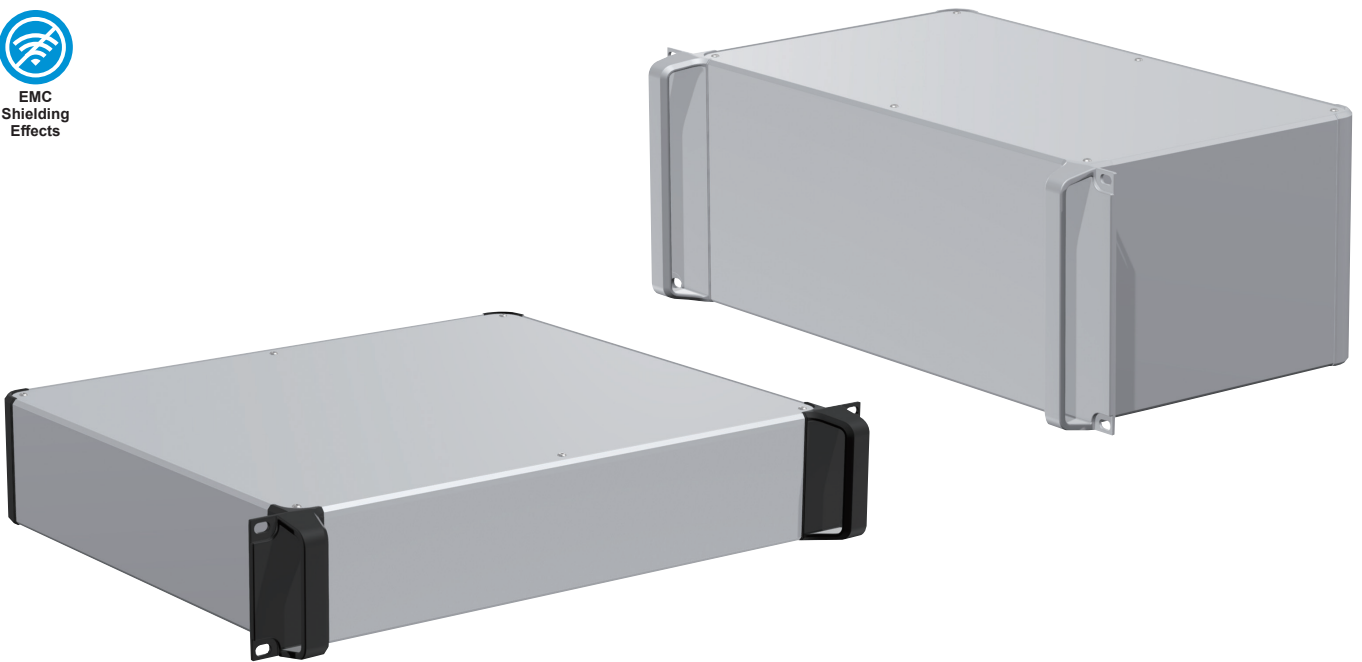

- EMC shielded 19" Rack Mount Enclosure with 4 extruded aluminium frames.
- Flat and rugged design rack mounting aluminium case with handles.
- A large selection of 28 different sizes in 2 different colors to choose from.
- Suitable for use as audio/visual equipment, communication equipment, rack mount computers, measuring instruments and others.

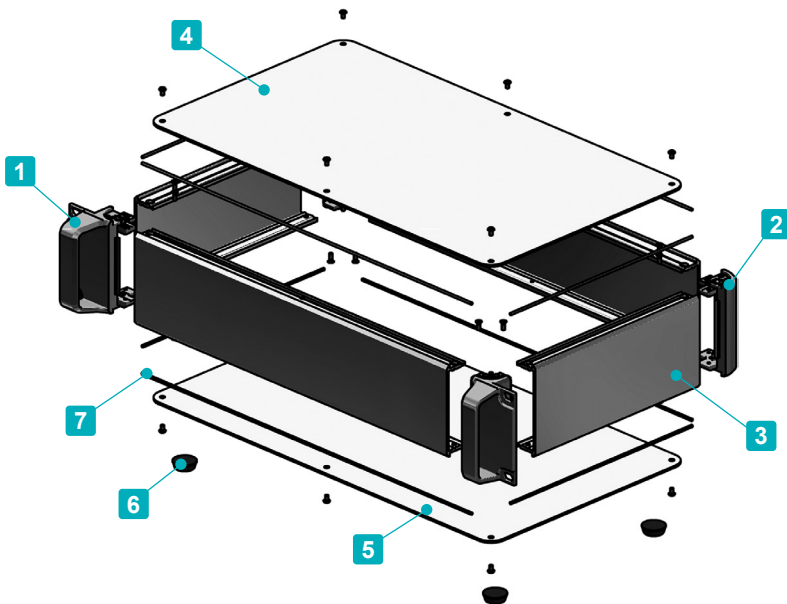

Included screws

- Top / Bottom cover
M3-5 original trapezoid head & Nickel plated x 8~16 pcs
- Frame
M3-8 flat head & Nickel plated x 16 pcs

Recommended torque : 0.3 ~ 0.6N • m

* Recommended torque listed is for reference only; actual may differ. Assemble after testing torque.

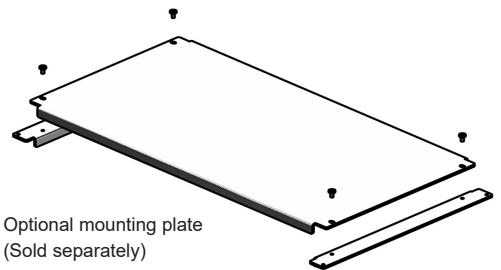

Components

No.	Part name	Pcs	Material	Color / Finish
1	Handle corner block	2	Diecast aluminium ADC12	Silver • Black / Painted (Unfinished inside)
2	Corner block	2	Diecast aluminium ADC12	Silver • Black / Painted (Unfinished inside)
3	Frame	4	Extruded aluminium A6063S-T5	Silver / Painted (Unfinished inside)
4	Top cover	1	Aluminium A1100P	Silver / Painted (Conductive inside)
5	Bottom cover	1	Aluminium A1100P	Silver / Painted (Conductive inside)
6	Rubber feet	4	Synthetic rubber	Black
7	EMC shielding gasket	8	Conductive fiber UL94V-0	Metallic gray

To select Screw and Color, follow steps **1** ~ **2** below to determine product number.

1 Screw

P Plus (Silver / Nickel plated)



H Hex (Silver / Nickel plated)

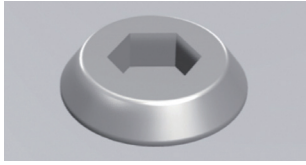

Hex wrench included.

2 Color

Please choose from the color combinations listed below.

S S



S B

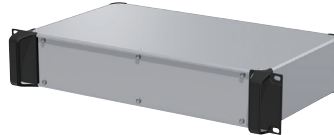

Product Number

To determine a product number, fill H-W-D dimensions and select Screw and Color code in the following blank boxes.

AUXRE



H-W-D dimensions

See below for dimensions / product no.



Screw

(P or H)



Color

(SS • SB)

Numbering example : If looking at "H88 x W430 x D250mm, Screw type H, Color type SB"

➔ **AUXRE 88-43-25 H-SB**

Product no. / Details ■ Please suffix screw and color code at the end of the product number.

Product no.	H	W	D	Weight (kg)
AUXRE 44-43-16□-□□	44	430	160	2.0
AUXRE 44-43-20□-□□	44	430	200	2.3
AUXRE 44-43-25□-□□	44	430	250	2.6
AUXRE 44-43-30□-□□	44	430	300	2.9
AUXRE 44-43-36□-□□	44	430	360	3.3
AUXRE 44-43-43□-□□	44	430	430	3.7
AUXRE 44-43-50□-□□	44	430	500	4.2
AUXRE 88-43-16□-□□	88	430	160	2.0
AUXRE 88-43-20□-□□	88	430	200	2.3
AUXRE 88-43-25□-□□	88	430	250	2.6
AUXRE 88-43-30□-□□	88	430	300	2.9
AUXRE 88-43-36□-□□	88	430	360	3.3
AUXRE 88-43-43□-□□	88	430	430	3.7
AUXRE 88-43-50□-□□	88	430	500	4.2
AUXRE133-43-16□-□□	132.5	430	160	2.6
AUXRE133-43-20□-□□	132.5	430	200	2.9
AUXRE133-43-25□-□□	132.5	430	250	3.3
AUXRE133-43-30□-□□	132.5	430	300	3.6
AUXRE133-43-36□-□□	132.5	430	360	4.1
AUXRE133-43-43□-□□	132.5	430	430	4.6
AUXRE133-43-50□-□□	132.5	430	500	5.1
AUXRE177-43-16□-□□	177	430	160	3.0
AUXRE177-43-20□-□□	177	430	200	3.4
AUXRE177-43-25□-□□	177	430	250	3.8
AUXRE177-43-30□-□□	177	430	300	4.2
AUXRE177-43-36□-□□	177	430	360	4.6
AUXRE177-43-43□-□□	177	430	430	5.2
AUXRE177-43-50□-□□	177	430	500	5.8

AUXRE dimensions

■ DXF/DWG/PDF/STP drawings available on our website.

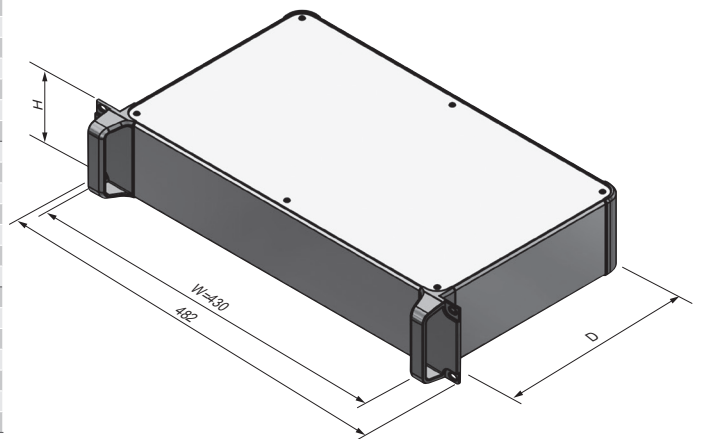

Accessories (Optional parts)

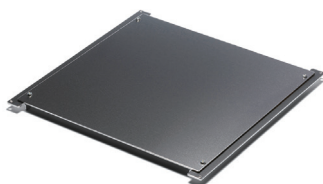

Mounting plate AUC series
See page 179 ~ 180



Rack mounting screw RT series
See page RT • RZ • RW



Rack mounting screw RZ series
See page RT • RZ • RW



EMC
Shielding
Effects



- Elegantly designed EMC shielded aluminium enclosure with detachable front/rear panels.
- Suitable to be used as an easy maintenance desktop case due to its detachable front/rear panels. Captive screws allow for ease of maintenance as there is little risk of the screws dropping out and getting lost.
- A large selection of 177 different sizes and 2 colors to choose from.
- Suitable for use as measuring instrument, controller, industrial embedded computer, power supply, audio amplifier, and others.

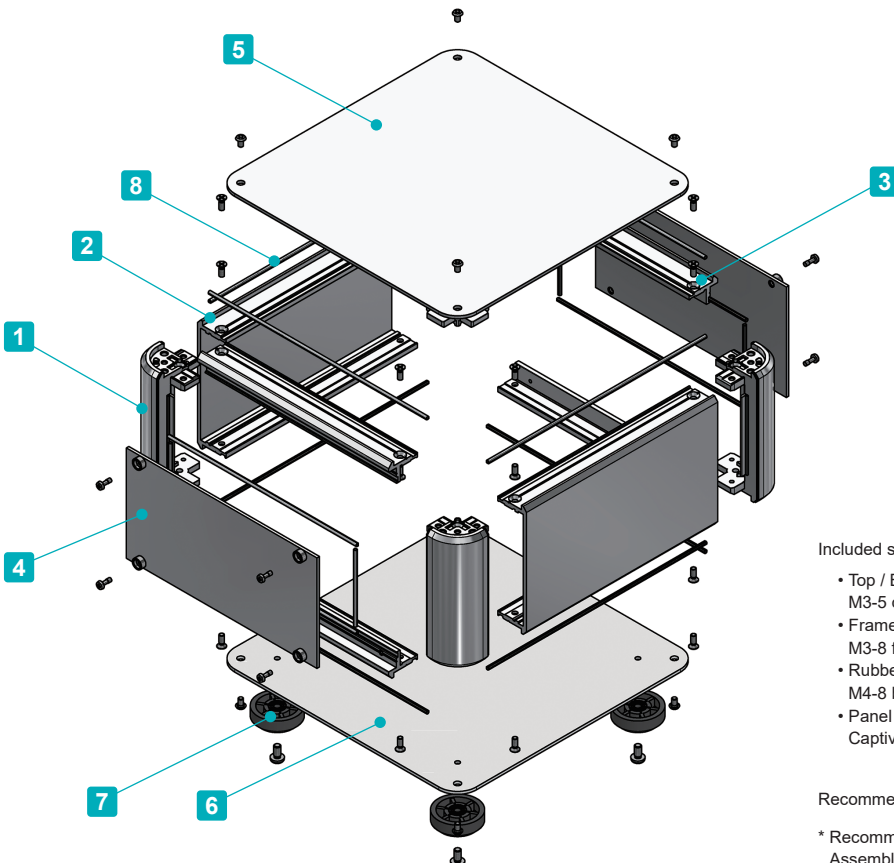

Included screws

- Top / Bottom cover
M3-5 original trapezoid head (plus / hex) & Nickel plated x 8~16 pcs
- Frame / Panel support frame
M3-8 flat head & Nickel plated x 16 pcs
- Rubber feet / Aluminium feet
M4-8 blind head & Black trivalent chromate x 4 pcs
- Panel
Captive M2.5-7 pan head & Nickel plated x 8 ~ 12 pcs

Recommended torque : $\begin{cases} \text{M2.5 : } 0.15 \sim 0.2\text{N} \cdot \text{m} \\ \text{M3 / M4 : } 0.3 \sim 0.6\text{N} \cdot \text{m} \end{cases}$

* Recommended torque listed is for reference only; actual may differ. Assemble after testing torque.

Components

No.	Part name	Pcs	Material	Color / Finish
1	Corner block	4	Diecast aluminium ADC12	Silver • Black / Painted (Unfinished inside)
2	Frame	2	Extruded aluminium A6063S-T5	Silver / Painted (Unfinished inside)
3	Panel support frame	4	Extruded aluminium A6063S-T5	Silver / Painted (Unfinished inside)
4	Panel	2	Aluminium A1100P	Silver / Painted (Conductive inside)
5	Top cover	1	Aluminium A1100P	Silver / Painted (Conductive inside)
6	Bottom cover	1	Aluminium A1100P	Silver / Painted (Conductive inside)
7	Rubber feet : Aluminium feet	4	TPE (Elastomer) : Aluminium	Black : Silver / Anodized
8	EMC shielding gasket	16	Conductive fiber UL94V-0	Metallic gray

To select Feet, Screw, and Color, follow steps **1** ~ **3** to determine product number.

1 Feet

R Rubber (Black)

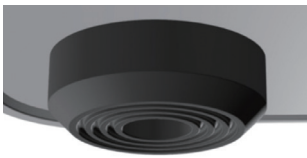

A Aluminium (Silver / Anodized)

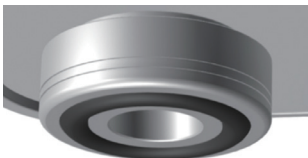

2 Screw

P Plus (Silver / Nickel plated)

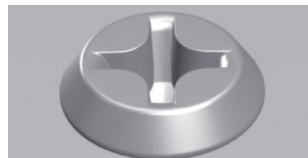

H Hex (Silver / Nickel plated)

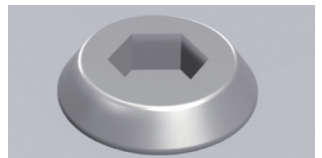

Hex wrench included.

3 Color

Please choose from the color combinations listed below.

S S

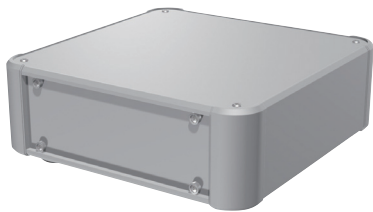

S B

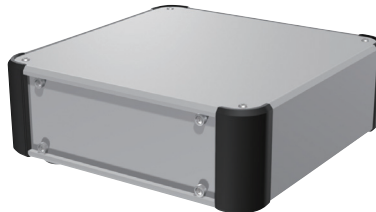

Product Number

To determine a product number, fill H-W-D dimensions and select Feet, Screw, and Color code in the following blank boxes.

AUPE

- -

H-W-D dimensions

See page 161~162 for dimensions and product no.

1 Feet **2 Screw**

R or A P or H

3 Color

SS or SB

Numbering example :

If looking at "H132.5 x W300 x D200mm, Feet type A, Screw type H, Color type SS"

➔ **AUPE 133-30-20 AH-SS**

Accessories (Optional parts)

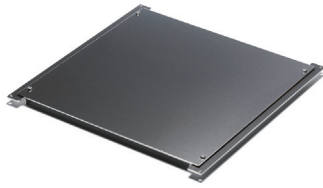

Mounting plate AUC series
See page 179 ~ 180



Elastomer carrying handle FM200
See page FM200 • MH



Tilt leg TLW series
See page 222

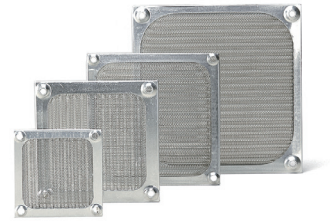

EMC shielding fan filter EMF series
See page Fan-4

AUPE dimensions

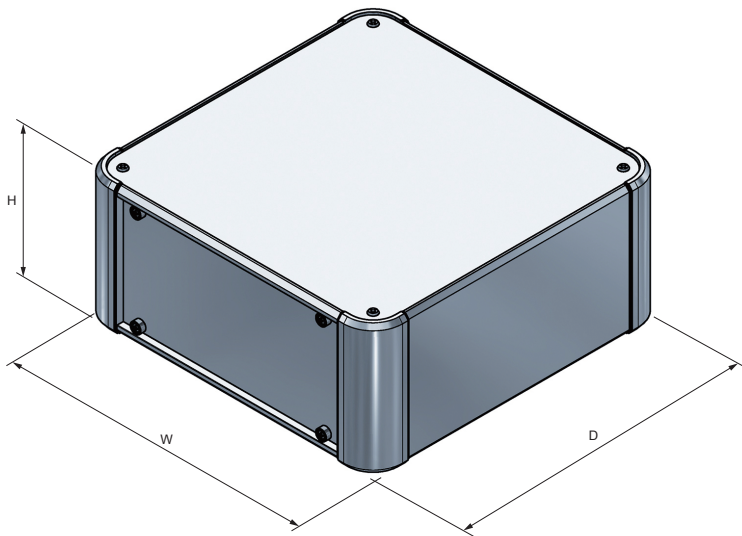

■ DXF/DWG/PDF/STP drawings available on our website.

■ Feet is selectable between rubber or aluminium type.
※Rubber and aluminium feet height are different.

Rubber Feet



Aluminium Feet



Product no. / Details

■ Please suffix color code at the end of the product number.

Product no.	H	W	D	Weight (kg)
AUPE 66-16-16□□-□□	66	160	160	0.9
AUPE 66-16-20□□-□□	66	160	200	1.0
AUPE 66-16-25□□-□□	66	160	250	1.2
AUPE 66-16-30□□-□□	66	160	300	1.4
NEW AUPE 66-16-36□□-□□	66	160	360	1.5
NEW AUPE 66-16-43□□-□□	66	160	430	1.8
AUPE 66-20-16□□-□□	66	200	160	1.0
AUPE 66-20-20□□-□□	66	200	200	1.2
AUPE 66-20-25□□-□□	66	200	250	1.4
AUPE 66-20-30□□-□□	66	200	300	1.5
AUPE 66-20-36□□-□□	66	200	360	1.8
AUPE 66-20-43□□-□□	66	200	430	2.0
AUPE 66-25-16□□-□□	66	250	160	1.2
AUPE 66-25-20□□-□□	66	250	200	1.4
AUPE 66-25-25□□-□□	66	250	250	1.6
AUPE 66-25-30□□-□□	66	250	300	1.8
AUPE 66-25-36□□-□□	66	250	360	2.0
AUPE 66-25-43□□-□□	66	250	430	2.3
AUPE 66-30-16□□-□□	66	300	160	1.4
AUPE 66-30-20□□-□□	66	300	200	1.6
AUPE 66-30-25□□-□□	66	300	250	1.8
AUPE 66-30-30□□-□□	66	300	300	2.0

Product no.	H	W	D	Weight (kg)
AUPE 66-30-36□□-□□	66	300	360	2.3
AUPE 66-30-43□□-□□	66	300	430	2.6
AUPE 66-30-50□□-□□	66	300	500	3.0
NEW AUPE 66-36-16□□-□□	66	360	160	1.6
AUPE 66-36-20□□-□□	66	360	200	1.8
AUPE 66-36-25□□-□□	66	360	250	2.0
AUPE 66-36-30□□-□□	66	360	300	2.3
AUPE 66-36-36□□-□□	66	360	360	2.6
AUPE 66-36-43□□-□□	66	360	430	3.0
AUPE 66-36-50□□-□□	66	360	500	3.4
NEW AUPE 66-43-16□□-□□	66	430	160	1.8
AUPE 66-43-20□□-□□	66	430	200	2.1
AUPE 66-43-25□□-□□	66	430	250	2.4
AUPE 66-43-30□□-□□	66	430	300	2.7
AUPE 66-43-36□□-□□	66	430	360	3.0
AUPE 66-43-43□□-□□	66	430	430	3.4
AUPE 66-43-50□□-□□	66	430	500	3.9
AUPE 66-50-30□□-□□	66	500	300	3.0
AUPE 66-50-36□□-□□	66	500	360	3.4
AUPE 66-50-43□□-□□	66	500	430	3.9
AUPE 66-50-50□□-□□	66	500	500	4.3

Product no. / Details

■ Please suffix color code at the end of the product number.

Product no.	H	W	D	Weight (kg)
AUPE 88-16-16□□-□□	88	160	160	1.0
AUPE 88-16-20□□-□□	88	160	200	1.2
AUPE 88-16-25□□-□□	88	160	250	1.3
AUPE 88-16-30□□-□□	88	160	300	1.5
NEW AUPE 88-16-36□□-□□	88	160	360	1.7
NEW AUPE 88-16-43□□-□□	88	160	430	2.0
AUPE 88-20-16□□-□□	88	200	160	1.2
AUPE 88-20-20□□-□□	88	200	200	1.3
AUPE 88-20-25□□-□□	88	200	250	1.5
AUPE 88-20-30□□-□□	88	200	300	1.7
AUPE 88-20-36□□-□□	88	200	360	1.9
AUPE 88-20-43□□-□□	88	200	430	2.2
AUPE 88-25-16□□-□□	88	250	160	1.3
AUPE 88-25-20□□-□□	88	250	200	1.5
AUPE 88-25-25□□-□□	88	250	250	1.7
AUPE 88-25-30□□-□□	88	250	300	1.9
AUPE 88-25-36□□-□□	88	250	360	2.2
AUPE 88-25-43□□-□□	88	250	430	2.5
AUPE 88-30-16□□-□□	88	300	160	1.5
AUPE 88-30-20□□-□□	88	300	200	1.7
AUPE 88-30-25□□-□□	88	300	250	1.9
AUPE 88-30-30□□-□□	88	300	300	2.2
AUPE 88-30-36□□-□□	88	300	360	2.5
AUPE 88-30-43□□-□□	88	300	430	2.9
AUPE 88-30-50□□-□□	88	300	500	3.2
NEW AUPE 88-36-16□□-□□	88	360	160	1.7
AUPE 88-36-20□□-□□	88	360	200	1.9
AUPE 88-36-25□□-□□	88	360	250	2.2
AUPE 88-36-30□□-□□	88	360	300	2.5
AUPE 88-36-36□□-□□	88	360	360	2.8
AUPE 88-36-43□□-□□	88	360	430	3.2
AUPE 88-36-50□□-□□	88	360	500	3.6
NEW AUPE 88-43-16□□-□□	88	430	160	2.0
AUPE 88-43-20□□-□□	88	430	200	2.2
AUPE 88-43-25□□-□□	88	430	250	2.6
AUPE 88-43-30□□-□□	88	430	300	2.9
AUPE 88-43-36□□-□□	88	430	360	3.3
AUPE 88-43-43□□-□□	88	430	430	3.7
AUPE 88-43-50□□-□□	88	430	500	4.1
AUPE 88-50-30□□-□□	88	500	300	3.2
AUPE 88-50-36□□-□□	88	500	360	3.6
AUPE 88-50-43□□-□□	88	500	430	4.1
AUPE 88-50-50□□-□□	88	500	500	4.6
AUPE133-16-16□□-□□	132.5	160	160	1.3
AUPE133-16-20□□-□□	132.5	160	200	1.4
AUPE133-16-25□□-□□	132.5	160	250	1.7
AUPE133-16-30□□-□□	132.5	160	300	1.9
NEW AUPE133-16-36□□-□□	132.5	160	360	2.1
NEW AUPE133-16-43□□-□□	132.5	160	430	2.5
AUPE133-20-16□□-□□	132.5	200	160	1.4
AUPE133-20-20□□-□□	132.5	200	200	1.6
AUPE133-20-25□□-□□	132.5	200	250	1.9
AUPE133-20-30□□-□□	132.5	200	300	2.1
AUPE133-20-36□□-□□	132.5	200	360	2.4
AUPE133-20-43□□-□□	132.5	200	430	2.7
AUPE133-25-16□□-□□	132.5	250	160	1.6
AUPE133-25-20□□-□□	132.5	250	200	1.8
AUPE133-25-25□□-□□	132.5	250	250	2.1
AUPE133-25-30□□-□□	132.5	250	300	2.4
AUPE133-25-36□□-□□	132.5	250	360	2.7
AUPE133-25-43□□-□□	132.5	250	430	3.1
AUPE133-30-16□□-□□	132.5	300	160	1.8
AUPE133-30-20□□-□□	132.5	300	200	2.1
AUPE133-30-25□□-□□	132.5	300	250	2.3
AUPE133-30-30□□-□□	132.5	300	300	2.6
AUPE133-30-36□□-□□	132.5	300	360	3.0
AUPE133-30-43□□-□□	132.5	300	430	3.4
AUPE133-30-50□□-□□	132.5	300	500	3.8
NEW AUPE133-36-16□□-□□	132.5	360	160	2.3
NEW AUPE133-36-20□□-□□	132.5	360	200	2.6
NEW AUPE133-36-25□□-□□	132.5	360	250	3.0
NEW AUPE133-36-30□□-□□	132.5	360	300	3.3
NEW AUPE133-36-36□□-□□	132.5	360	360	3.8
NEW AUPE133-36-43□□-□□	132.5	360	430	4.3
NEW AUPE133-36-50□□-□□	132.5	360	500	4.8
NEW AUPE133-43-16□□-□□	132.5	430	160	2.7
NEW AUPE133-43-20□□-□□	132.5	430	200	3.0
NEW AUPE133-43-25□□-□□	132.5	430	250	3.4
NEW AUPE133-43-30□□-□□	132.5	430	300	3.8
NEW AUPE133-43-36□□-□□	132.5	430	360	4.2
NEW AUPE133-43-43□□-□□	132.5	430	430	4.8
NEW AUPE133-43-50□□-□□	132.5	430	500	5.4
NEW AUPE133-50-30□□-□□	132.5	500	300	4.2
NEW AUPE133-50-36□□-□□	132.5	500	360	4.7
NEW AUPE133-50-43□□-□□	132.5	500	430	5.3
NEW AUPE133-50-50□□-□□	132.5	500	500	5.9

Product no.	H	W	D	Weight (kg)
AUPE133-30-36□□-□□	132.5	300	360	3.0
AUPE133-30-43□□-□□	132.5	300	430	3.4
AUPE133-30-50□□-□□	132.5	300	500	3.8
NEW AUPE133-36-16□□-□□	132.5	360	160	2.1
AUPE133-36-20□□-□□	132.5	360	200	2.3
AUPE133-36-25□□-□□	132.5	360	250	2.6
AUPE133-36-30□□-□□	132.5	360	300	3.0
AUPE133-36-36□□-□□	132.5	360	360	3.4
AUPE133-36-43□□-□□	132.5	360	430	3.8
AUPE133-36-50□□-□□	132.5	360	500	4.3
NEW AUPE133-43-16□□-□□	132.5	430	160	2.4
AUPE133-43-20□□-□□	132.5	430	200	2.7
AUPE133-43-25□□-□□	132.5	430	250	3.0
AUPE133-43-30□□-□□	132.5	430	300	3.4
AUPE133-43-36□□-□□	132.5	430	360	3.8
AUPE133-43-43□□-□□	132.5	430	430	4.3
AUPE133-43-50□□-□□	132.5	430	500	4.8
AUPE133-50-30□□-□□	132.5	500	300	3.8
AUPE133-50-36□□-□□	132.5	500	360	4.2
AUPE133-50-43□□-□□	132.5	500	430	4.8
AUPE133-50-50□□-□□	132.5	500	500	5.4
NEW AUPE177-16-16□□-□□	177	160	160	1.4
NEW AUPE177-16-20□□-□□	177	160	200	1.6
NEW AUPE177-16-25□□-□□	177	160	250	1.9
NEW AUPE177-16-30□□-□□	177	160	300	2.1
NEW AUPE177-16-36□□-□□	177	160	360	2.4
NEW AUPE177-16-43□□-□□	177	160	430	2.8
NEW AUPE177-20-16□□-□□	177	200	160	1.6
NEW AUPE177-20-20□□-□□	177	200	200	1.8
NEW AUPE177-20-25□□-□□	177	200	250	2.1
NEW AUPE177-20-30□□-□□	177	200	300	2.4
NEW AUPE177-20-36□□-□□	177	200	360	2.7
NEW AUPE177-20-43□□-□□	177	200	430	3.1
NEW AUPE177-25-16□□-□□	177	250	160	1.8
NEW AUPE177-25-20□□-□□	177	250	200	2.1
NEW AUPE177-25-25□□-□□	177	250	250	2.4
NEW AUPE177-25-30□□-□□	177	250	300	2.7
NEW AUPE177-25-36□□-□□	177	250	360	3.0
NEW AUPE177-25-43□□-□□	177	250	430	3.5
NEW AUPE177-30-16□□-□□	177	300	160	2.0
NEW AUPE177-30-20□□-□□	177	300	200	2.3
NEW AUPE177-30-25□□-□□	177	300	250	2.6
NEW AUPE177-30-30□□-□□	177	300	300	3.0
NEW AUPE177-30-36□□-□□	177	300	360	3.4
NEW AUPE177-30-43□□-□□	177	300	430	3.8
NEW AUPE177-30-50□□-□□	177	300	500	4.3
NEW AUPE177-36-16□□-□□	177	360	160	2.3
NEW AUPE177-36-20□□-□□	177	360	200	2.6
NEW AUPE177-36-25□□-□□	177	360	250	3.0
NEW AUPE177-36-30□□-□□	177	360	300	3.3
NEW AUPE177-36-36□□-□□	177	360	360	3.8
NEW AUPE177-36-43□□-□□	177	360	430	4.3
NEW AUPE177-36-50□□-□□	177	360	500	4.8
NEW AUPE177-43-16□□-□□	177	430	160	2.7
NEW AUPE177-43-20□□-□□	177	430	200	3.0
NEW AUPE177-43-25□□-□□	177	430	250	3.4
NEW AUPE177-43-30□□-□□	177	430	300	3.8
NEW AUPE177-43-36□□-□□	177	430	360	4.2
NEW AUPE177-43-43□□-□□	177	430	430	4.8
NEW AUPE177-43-50□□-□□	177	430	500	5.4
NEW AUPE177-50-30□□-□□	177	500	300	4.2
NEW AUPE177-50-36□□-□□	177	500	360	4.7
NEW AUPE177-50-43□□-□□	177	500	430	5.3
NEW AUPE177-50-50□□-□□	177	500	500	5.9



EMC
Shielding
Effects

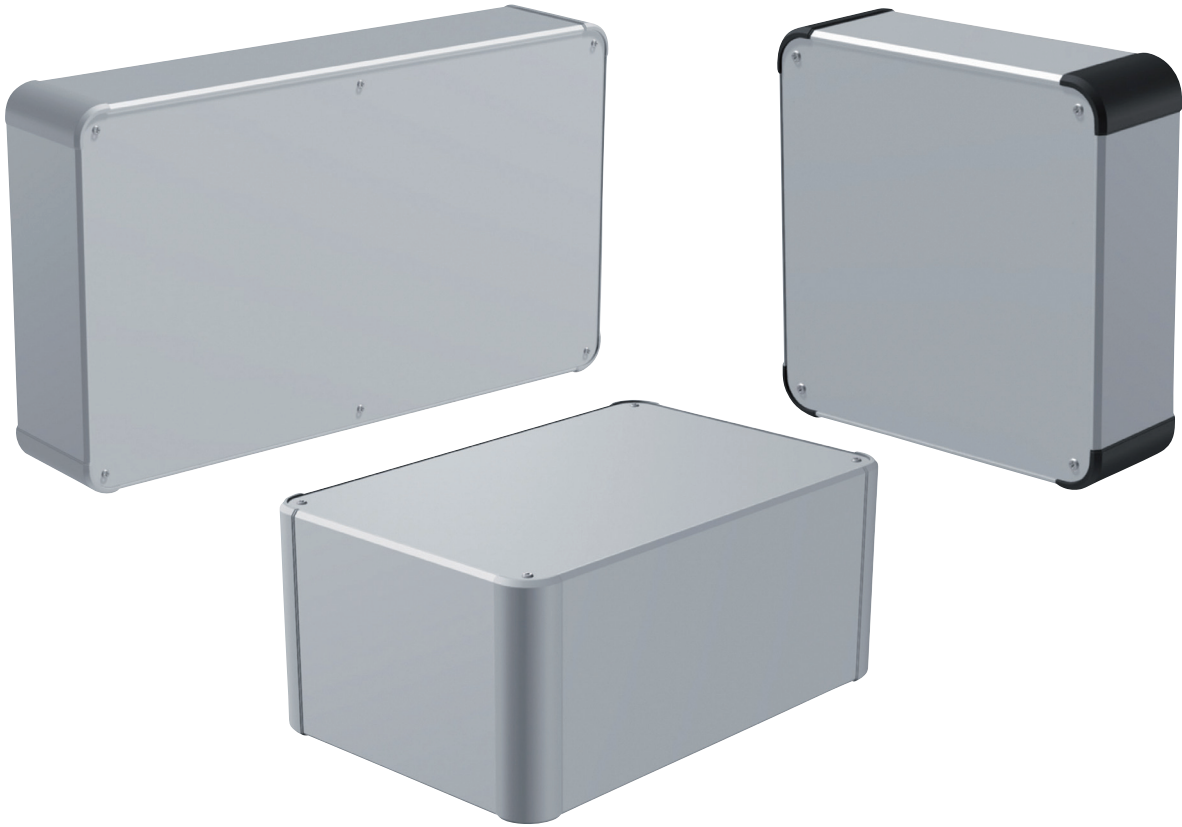

- Round corner designed aluminium enclosure with 4 extruded aluminium frames.
- Shielding gasket allows the enclosure to be EMC shielded.
- A large selection of 135 different sizes and 2 colors to choose from.
- Feet is selectable between adhesive rubber or aluminium type.

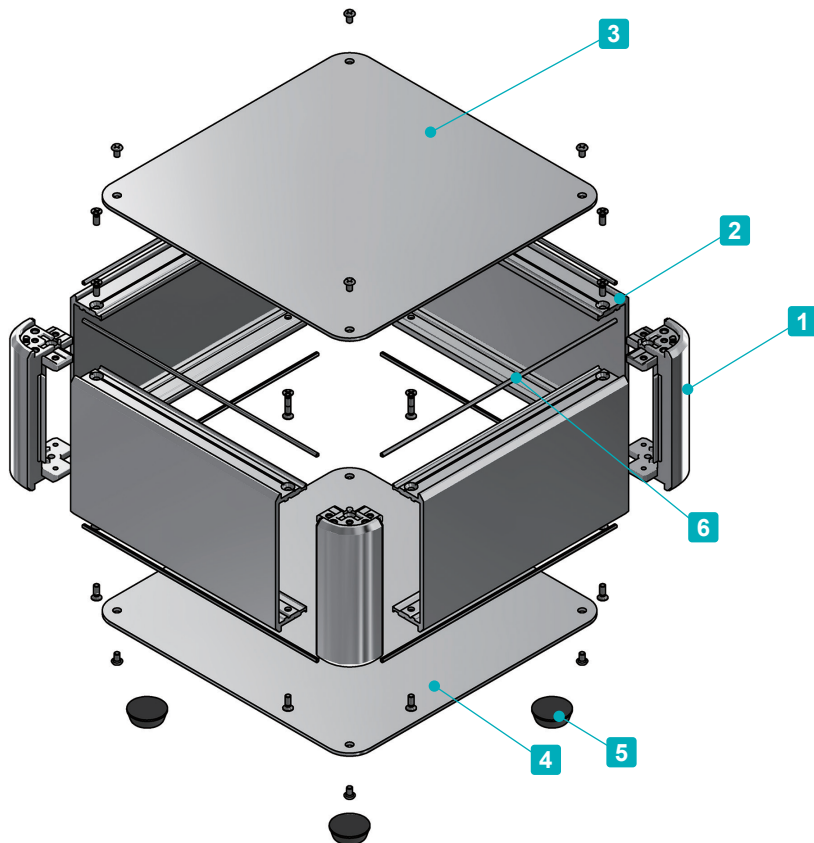

Included screws

- Top / Bottom cover
M3-5 original trapezoid head (plus / hex) & Nickel plated x 8~16 pcs
- Frame
M3-8 flat head & Nickel plated x 16 pcs
- Aluminium feet
M4-8 bind head & Black trivalent chromate x 4 pcs

Recommended torque : 0.3 ~ 0.6N • m

* Recommended torque listed is for reference only; actual may differ.
Assemble after testing torque.

Components

No.	Part name	Pcs	Material	Color / Finish
1	Corner block	4	Diecast aluminium ADC12	Silver • Black / Painted (Unfinished inside)
2	Frame	4	Extruded aluminium A6063S-T5	Silver / Painted (Unfinished inside)
3	Top cover	1	Aluminium A1100P	Silver / Painted (Conductive inside)
4	Bottom cover	1	Aluminium A1100P	Silver / Painted (Conductive inside)
5	Adhesive Rubber feet : Aluminium feet	4	Synthetic rubber : Aluminium	Black : Silver / Anodized
6	EMC shielding gasket	8	Conductive fiber UL94V-0	Metallic gray

To select Feet, Screw, and Color, follow steps **1** ~ **3** to determine product number.

1 Feet

R Rubber (Black / Unfinished) **A** Aluminium (Silver / Anodized)

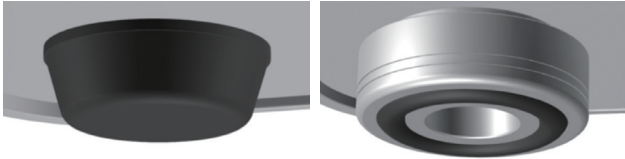

*Color of "Aluminium Feet" will be the same as bottom cover color.

2 Screw

P Plus (Silver / Nickel plated) **H** Hex (Silver / Nickel plated)

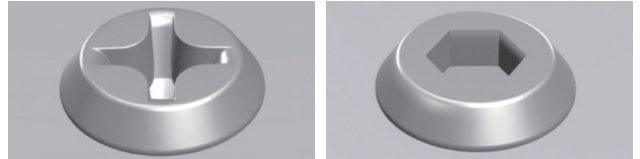

Hex wrench included.

3 Color

Please choose from the color combinations listed below.

S S



S B



Product Number

To determine a product number, fill H-W-D dimensions and select Feet, Screw, and Color code in the following blank boxes.

AUXE

- -

H-W-D dimensions

See page 169~170 for dimensions and product no.

1 Feet **2** Screw

R or A P or H

3 Color

SS or SB

Numbering example :

If looking at "H132.5 x W300 x D300mm, Feet type R, Screw type P, Color type SB"

➔ **AUXE 133-30-30 RP-SB**

Accessories (Optional parts)



Mounting plate AUC series
See page 179 ~ 180

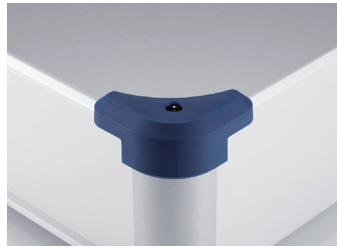

Corner guard AUCG series
See page 180



Elastomer carrying handle FM200
See page FM200 • MH



Aluminium handle OH series
See page OH • KH-1



Wall mount support arm MAR series
See page 181 ~ 182

AUXE dimensions

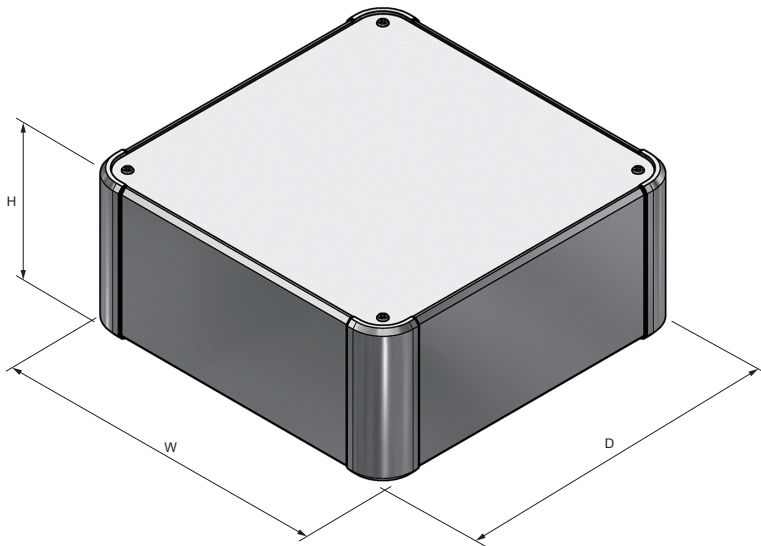

■ DXF/DWG/PDF/STP drawings available on our website.

■ Feet is selectable between rubber or aluminium type.
※Rubber and aluminium feet height are different.

Rubber Feet



Aluminium Feet

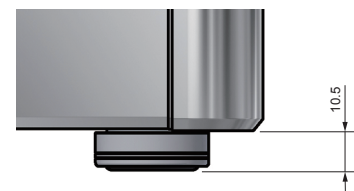

Product no. / Details

■ Please suffix color code at the end of the product number.

Product no.	H	W	D	Weight (kg)
NEW AUXE 44-16-16□□-□□	44	160	160	0.7
NEW AUXE 44-20-16□□-□□	44	200	160	0.8
NEW AUXE 44-20-20□□-□□	44	200	200	0.9
NEW AUXE 44-25-16□□-□□	44	250	160	1.0
NEW AUXE 44-25-20□□-□□	44	250	200	1.1
NEW AUXE 44-25-25□□-□□	44	250	250	1.3
NEW AUXE 44-30-16□□-□□	44	300	160	1.1
NEW AUXE 44-30-20□□-□□	44	300	200	1.3
NEW AUXE 44-30-25□□-□□	44	300	250	1.5
NEW AUXE 44-30-30□□-□□	44	300	300	1.7
NEW AUXE 44-36-16□□-□□	44	360	160	1.2
NEW AUXE 44-36-20□□-□□	44	360	200	1.5
NEW AUXE 44-36-25□□-□□	44	360	250	1.7
NEW AUXE 44-36-30□□-□□	44	360	300	2.0

Product no.	H	W	D	Weight (kg)
NEW AUXE 44-36-36□□-□□	44	360	360	2.3
NEW AUXE 44-43-16□□-□□	44	430	160	1.5
NEW AUXE 44-43-20□□-□□	44	430	200	1.7
NEW AUXE 44-43-25□□-□□	44	430	250	2.0
NEW AUXE 44-43-30□□-□□	44	430	300	2.3
NEW AUXE 44-43-36□□-□□	44	430	360	2.6
NEW AUXE 44-43-43□□-□□	44	430	430	3.0
NEW AUXE 44-50-30□□-□□	44	500	300	2.6
NEW AUXE 44-50-36□□-□□	44	500	360	3.0
NEW AUXE 44-50-43□□-□□	44	500	430	3.4
NEW AUXE 44-50-50□□-□□	44	500	500	3.9
NEW AUXE 44-60-36□□-□□	44	600	360	3.5
NEW AUXE 44-60-43□□-□□	44	600	430	4.0

Product no. / Details

■ Please suffix color code at the end of the product number.

Product no.	H	W	D	Weight (kg)
AUXE 66-16-16□□-□□	66	160	160	0.9
AUXE 66-20-16□□-□□	66	200	160	1.0
AUXE 66-20-20□□-□□	66	200	200	1.1
AUXE 66-25-16□□-□□	66	250	160	1.2
AUXE 66-25-20□□-□□	66	250	200	1.3
AUXE 66-25-25□□-□□	66	250	250	1.5
AUXE 66-30-16□□-□□	66	300	160	1.3
AUXE 66-30-20□□-□□	66	300	200	1.5
AUXE 66-30-25□□-□□	66	300	250	1.7
AUXE 66-30-30□□-□□	66	300	300	2.0
NEW AUXE 66-36-16□□-□□	66	360	160	1.4
AUXE 66-36-20□□-□□	66	360	200	1.7
AUXE 66-36-25□□-□□	66	360	250	2.0
AUXE 66-36-30□□-□□	66	360	300	2.2
AUXE 66-36-36□□-□□	66	360	360	2.6
NEW AUXE 66-43-16□□-□□	66	430	160	1.8
AUXE 66-43-20□□-□□	66	430	200	2.0
AUXE 66-43-25□□-□□	66	430	250	2.3
AUXE 66-43-30□□-□□	66	430	300	2.6
AUXE 66-43-36□□-□□	66	430	360	3.0
AUXE 66-43-43□□-□□	66	430	430	3.4
AUXE 66-50-30□□-□□	66	500	300	2.9
AUXE 66-50-36□□-□□	66	500	360	3.3
AUXE 66-50-43□□-□□	66	500	430	3.8
AUXE 66-50-50□□-□□	66	500	500	4.3
AUXE 66-60-36□□-□□	66	600	360	3.8
AUXE 66-60-43□□-□□	66	600	430	4.4
AUXE 88-16-16□□-□□	88	160	160	1.0
AUXE 88-20-16□□-□□	88	200	160	1.1
AUXE 88-20-20□□-□□	88	200	200	1.3
AUXE 88-25-16□□-□□	88	250	160	1.3
AUXE 88-25-20□□-□□	88	250	200	1.5
AUXE 88-25-25□□-□□	88	250	250	1.7
AUXE 88-30-16□□-□□	88	300	160	1.5
AUXE 88-30-20□□-□□	88	300	200	1.7
AUXE 88-30-25□□-□□	88	300	250	1.9
AUXE 88-30-30□□-□□	88	300	300	2.2
NEW AUXE 88-36-16□□-□□	88	360	160	1.6
AUXE 88-36-20□□-□□	88	360	200	1.9
AUXE 88-36-25□□-□□	88	360	250	2.2
AUXE 88-36-30□□-□□	88	360	300	2.4
AUXE 88-36-36□□-□□	88	360	360	2.8
NEW AUXE 88-43-16□□-□□	88	430	160	1.9
AUXE 88-43-20□□-□□	88	430	200	2.2
AUXE 88-43-25□□-□□	88	430	250	2.5
AUXE 88-43-30□□-□□	88	430	300	2.8
AUXE 88-43-36□□-□□	88	430	360	3.2
AUXE 88-43-43□□-□□	88	430	430	3.6
AUXE 88-50-30□□-□□	88	500	300	3.2
AUXE 88-50-36□□-□□	88	500	360	3.6
AUXE 88-50-43□□-□□	88	500	430	4.1
AUXE 88-50-50□□-□□	88	500	500	4.6
AUXE 88-60-36□□-□□	88	600	360	4.1
AUXE 88-60-43□□-□□	88	600	430	4.7

Product no.	H	W	D	Weight (kg)
AUXE133-16-16□□-□□	132.5	160	160	1.3
AUXE133-20-16□□-□□	132.5	200	160	1.5
AUXE133-20-20□□-□□	132.5	200	200	1.7
AUXE133-25-16□□-□□	132.5	250	160	1.7
AUXE133-25-20□□-□□	132.5	250	200	1.9
AUXE133-25-25□□-□□	132.5	250	250	2.2
AUXE133-30-16□□-□□	132.5	300	160	1.9
AUXE133-30-20□□-□□	132.5	300	200	2.1
AUXE133-30-25□□-□□	132.5	300	250	2.4
AUXE133-30-30□□-□□	132.5	300	300	2.7
NEW AUXE133-36-16□□-□□	132.5	360	160	2.2
AUXE133-36-20□□-□□	132.5	360	200	2.4
AUXE133-36-25□□-□□	132.5	360	250	2.7
AUXE133-36-30□□-□□	132.5	360	300	3.1
AUXE133-36-36□□-□□	132.5	360	360	3.4
NEW AUXE133-43-16□□-□□	132.5	430	160	2.5
AUXE133-43-20□□-□□	132.5	430	200	2.8
AUXE133-43-25□□-□□	132.5	430	250	3.1
AUXE133-43-30□□-□□	132.5	430	300	3.5
AUXE133-43-36□□-□□	132.5	430	360	3.9
AUXE133-43-43□□-□□	132.5	430	430	4.4
AUXE133-50-30□□-□□	132.5	500	300	3.9
AUXE133-50-36□□-□□	132.5	500	360	4.4
AUXE133-50-43□□-□□	132.5	500	430	4.9
AUXE133-50-50□□-□□	132.5	500	500	5.5
AUXE133-60-36□□-□□	132.5	600	360	5.0
AUXE133-60-43□□-□□	132.5	600	430	5.7
NEW AUXE177-16-16□□-□□	177	160	160	1.5
NEW AUXE177-20-16□□-□□	177	200	160	1.7
NEW AUXE177-20-20□□-□□	177	200	200	1.9
NEW AUXE177-25-16□□-□□	177	250	160	1.9
NEW AUXE177-25-20□□-□□	177	250	200	2.2
NEW AUXE177-25-25□□-□□	177	250	250	2.5
NEW AUXE177-30-16□□-□□	177	300	160	2.2
NEW AUXE177-30-20□□-□□	177	300	200	2.4
NEW AUXE177-30-25□□-□□	177	300	250	2.8
NEW AUXE177-30-30□□-□□	177	300	300	3.1
NEW AUXE177-36-16□□-□□	177	360	160	2.5
NEW AUXE177-36-20□□-□□	177	360	200	2.8
NEW AUXE177-36-25□□-□□	177	360	250	3.1
NEW AUXE177-36-30□□-□□	177	360	300	3.5
NEW AUXE177-36-36□□-□□	177	360	360	3.9
NEW AUXE177-43-16□□-□□	177	430	160	2.9
NEW AUXE177-43-20□□-□□	177	430	200	3.2
NEW AUXE177-43-25□□-□□	177	430	250	3.6
NEW AUXE177-43-30□□-□□	177	430	300	4.0
NEW AUXE177-43-36□□-□□	177	430	360	4.5
NEW AUXE177-43-43□□-□□	177	430	430	5.0
NEW AUXE177-50-30□□-□□	177	500	300	4.4
NEW AUXE177-50-36□□-□□	177	500	360	5.0
NEW AUXE177-50-43□□-□□	177	500	430	5.6
NEW AUXE177-50-50□□-□□	177	500	500	6.2
NEW AUXE177-60-36□□-□□	177	600	360	5.7
NEW AUXE177-60-43□□-□□	177	600	430	6.4

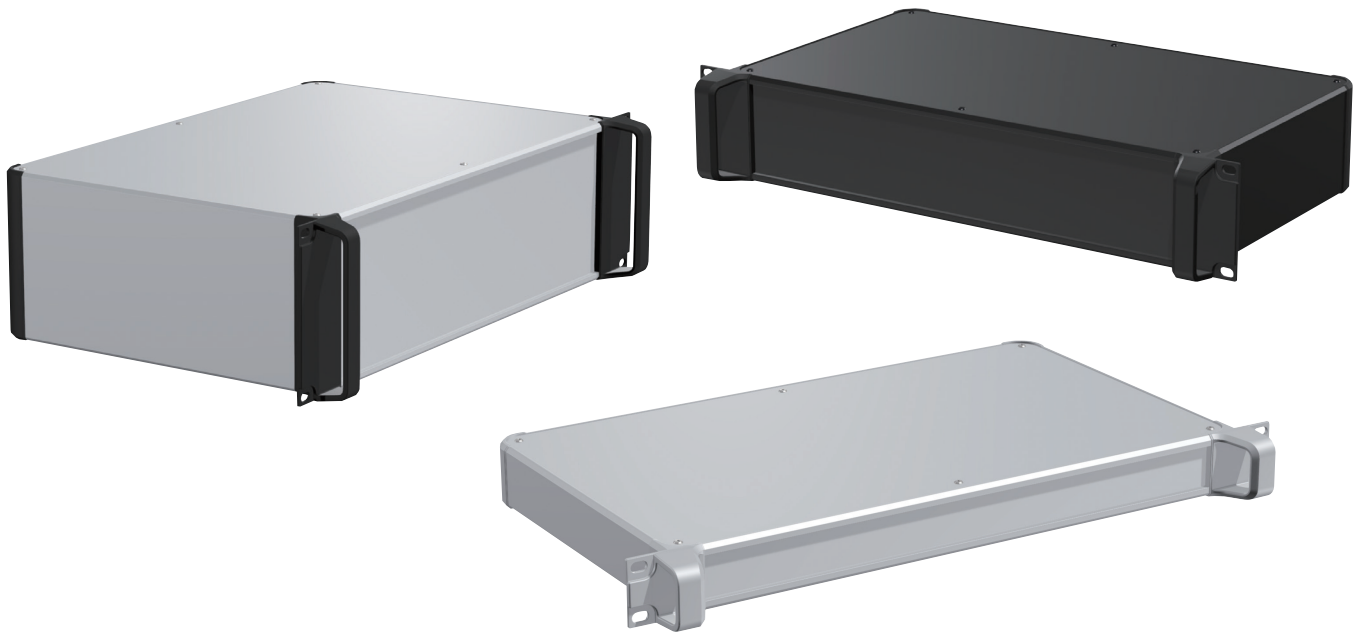

- 19" rack mount enclosure with insertion type front/rear panels, giving it a beautiful appearance.
- A large selection of 28 different sizes in 4 different colors to choose from.
- Suitable for use as audio/visual equipment, communication equipment, rack mount computers, measuring instruments and others.

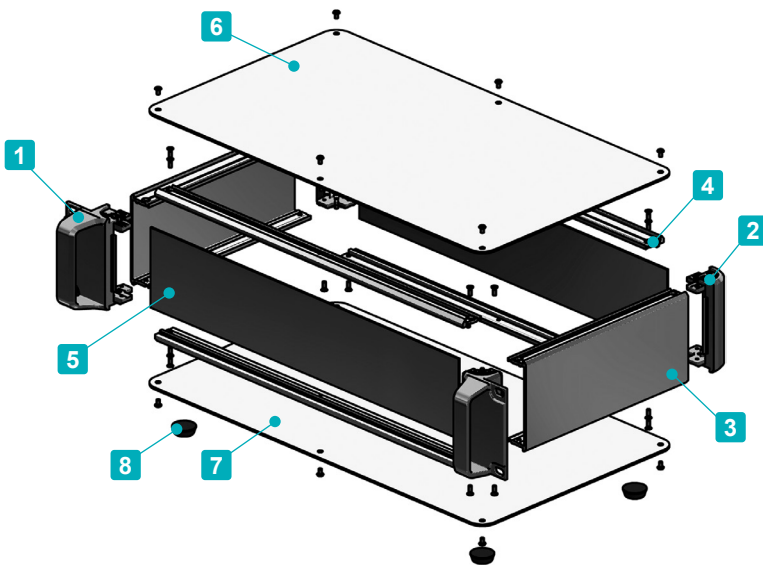

Included screws
 • Top / Bottom cover
 M3-5 original trapezoid head & Nickel plated x 8~16 pcs
 • Frame
 M3-8 flat head & Nickel plated x 16 pcs

Recommended torque : 0.3 ~ 0.6N • m
 * Recommended torque listed is for reference only; actual may differ. Assemble after testing torque.

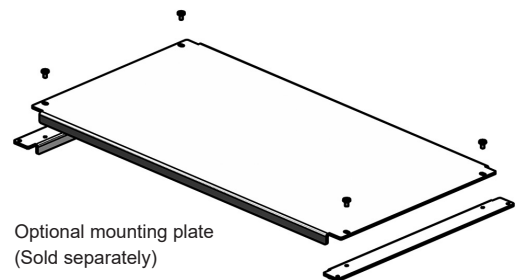

Components

No.	Part name	Pcs	Material	Color / Finish
1	Handle Corner Block	2	Diecast aluminium ADC12	Silver • Black / Painted (Unfinished inside)
2	Corner block	2	Diecast aluminium ADC12	Silver • Black / Painted (Unfinished inside)
3	Frame	2	Extruded aluminium A6063S-T5	Silver • Black / Anodized
4	Panel support frame	4	Extruded aluminium A6063S-T5	Silver • Black / Anodized
5	Panel	2	Aluminium A1100P	Silver • Black / Anodized
6	Top cover	1	Aluminium A1100P	Silver • Black / Anodized
7	Bottom cover	1	Aluminium A1100P	Silver • Black / Anodized
8	Rubber feet	4	Synthetic rubber	Black

To select Screw and Color, follow steps **1** ~ **2** below to determine product number.

1 Screw

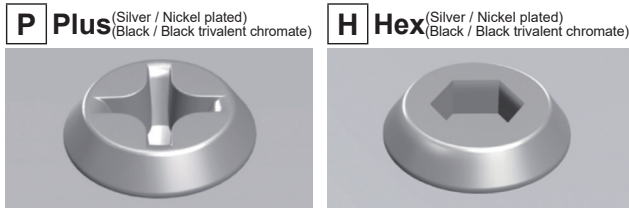

*Color of screw will be the same as top • bottom cover color.

Hex wrench included.

2 Color

Please choose from the color combinations listed below.

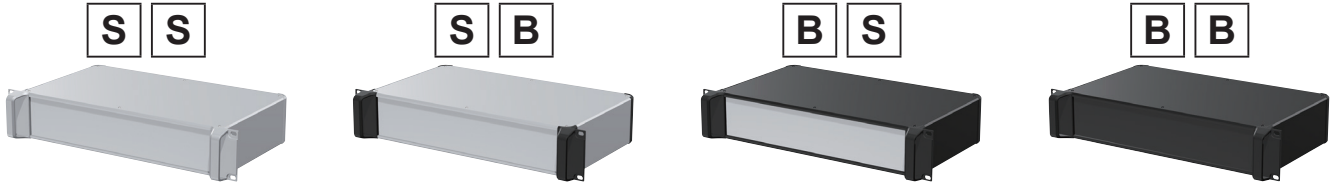

Product Number

To determine a product number, fill H-W-D dimensions and select Screw and Color code in the following blank boxes.

AUR - - -

H-W-D dimensions **Screw** **Color**

See below for dimensions / product no. (P or H) (SS • SB • BS • BB)

Numbering example : If looking at "H88 x W430 x D250mm, Screw type H, Color type BS"

➔ **AUR 88-43-25 H-BS**

Product no. / Details ■ Please suffix screw and color code at the end of the product number.

Product no.	H	W	D	Weight (kg)
AUR 44-43-16□-□□	44	430	160	1.5
AUR 44-43-20□-□□	44	430	200	1.8
AUR 44-43-25□-□□	44	430	250	2.0
AUR 44-43-30□-□□	44	430	300	2.3
AUR 44-43-36□-□□	44	430	360	2.7
AUR 44-43-43□-□□	44	430	430	3.1
AUR 44-43-50□-□□	44	430	500	3.5
AUR 88-43-16□-□□	88	430	160	1.9
AUR 88-43-20□-□□	88	430	200	2.1
AUR 88-43-25□-□□	88	430	250	2.5
AUR 88-43-30□-□□	88	430	300	2.8
AUR 88-43-36□-□□	88	430	360	3.2
AUR 88-43-43□-□□	88	430	430	3.6
AUR 88-43-50□-□□	88	430	500	4.1
AUR133-43-16□-□□	132.5	430	160	2.3
AUR133-43-20□-□□	132.5	430	200	2.6
AUR133-43-25□-□□	132.5	430	250	2.9
AUR133-43-30□-□□	132.5	430	300	3.3
AUR133-43-36□-□□	132.5	430	360	3.7
AUR133-43-43□-□□	132.5	430	430	4.2
AUR133-43-50□-□□	132.5	430	500	4.7
AUR177-43-16□-□□	177	430	160	2.6
AUR177-43-20□-□□	177	430	200	2.9
AUR177-43-25□-□□	177	430	250	3.3
AUR177-43-30□-□□	177	430	300	3.7
AUR177-43-36□-□□	177	430	360	4.2
AUR177-43-43□-□□	177	430	430	4.7
AUR177-43-50□-□□	177	430	500	5.3

AUR dimensions

■ DXF/DWG/PDF/STP drawings available on our website.

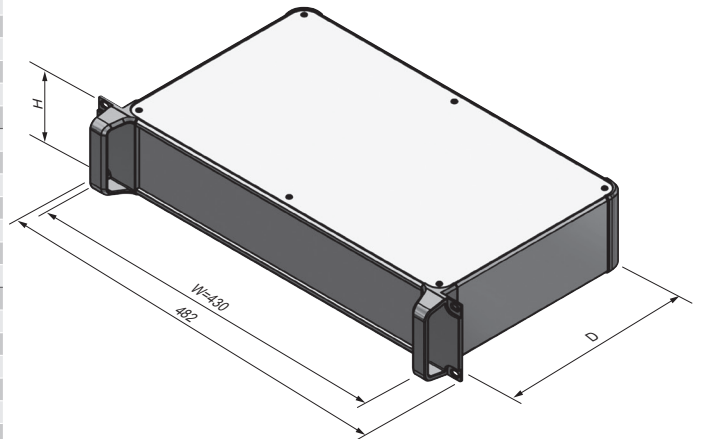

Accessories (Optional parts)

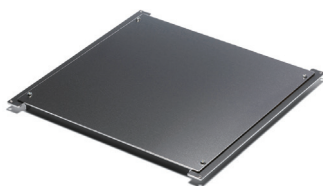

Mounting plate AUC series
See page 179 ~ 180



Rack mounting screw RT series
See page RT • RZ • RW



Rack mounting screw RZ series
See page RT • RZ • RW

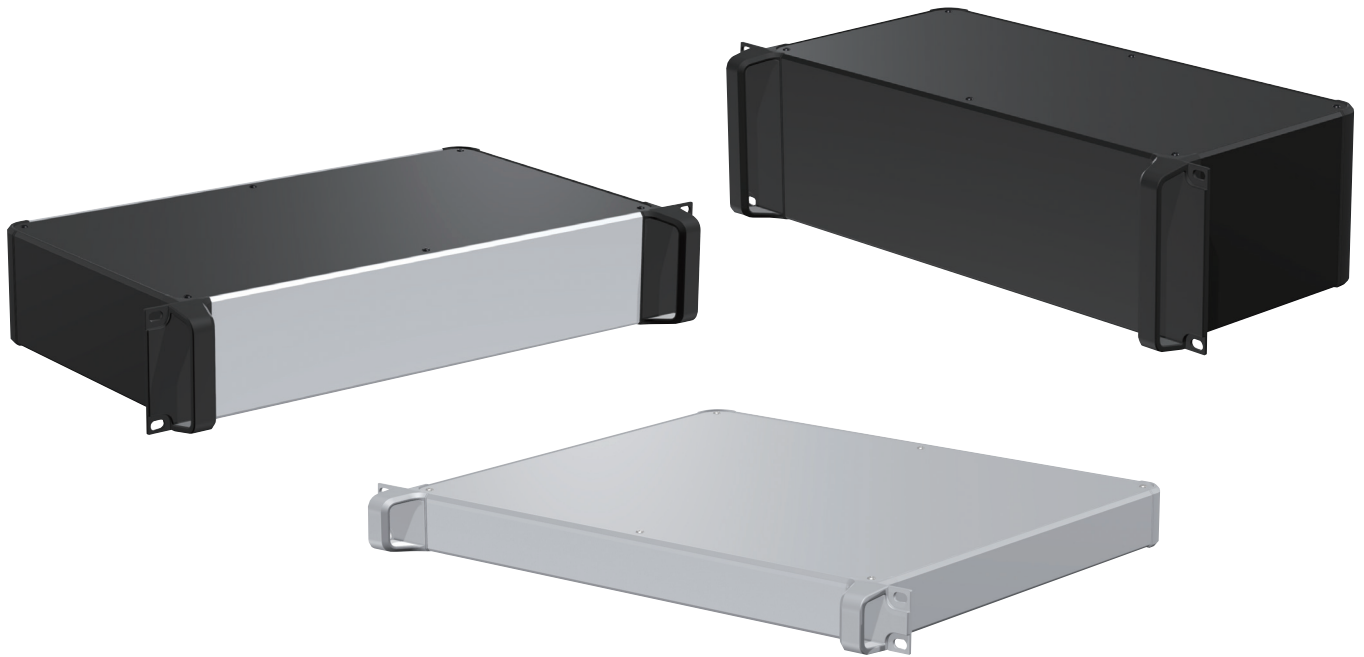

- 19" Rack Mount Enclosure with 4 extruded aluminium frames.
- Flat and rugged design rack mounting aluminium case with handles.
- A wide selection of 28 different sizes in 4 different colors to choose from.
- Suitable for use as audio/visual equipment, communication equipment, rack mount computers, measuring instruments and others.

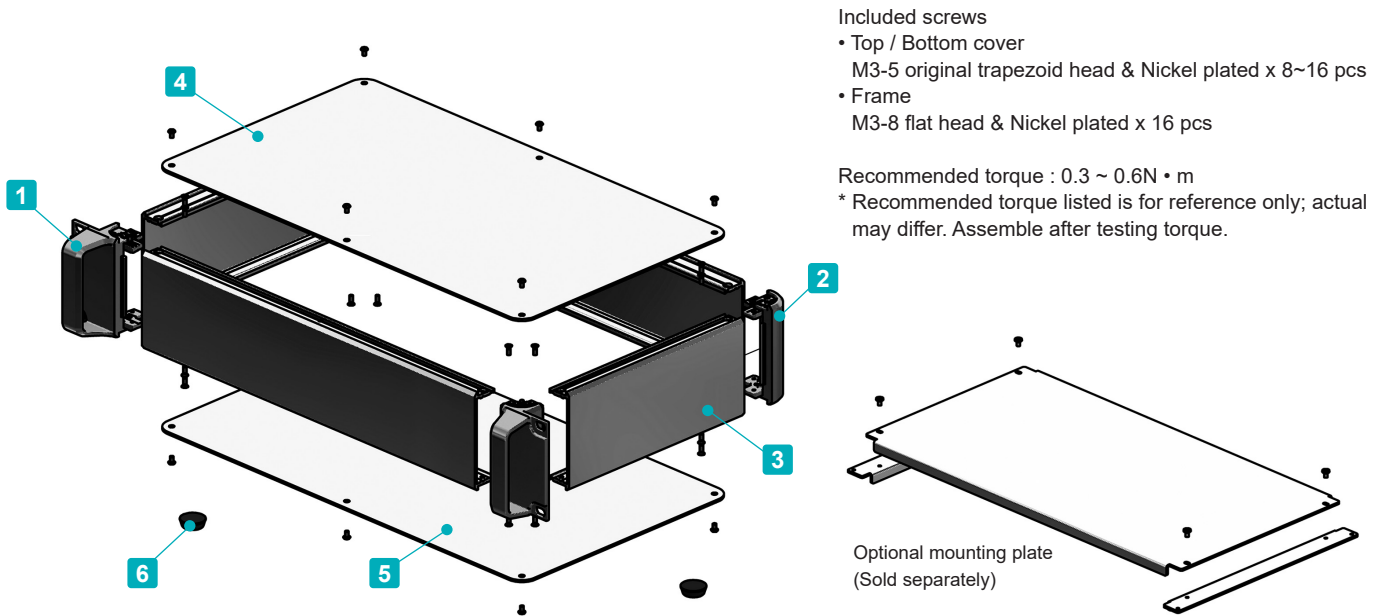

Included screws

- Top / Bottom cover
M3-5 original trapezoid head & Nickel plated x 8~16 pcs
- Frame
M3-8 flat head & Nickel plated x 16 pcs

Recommended torque : 0.3 ~ 0.6N · m

* Recommended torque listed is for reference only; actual may differ. Assemble after testing torque.

Components

No.	Part name	Pcs	Material	Color / Finish
1	Handle corner block	2	Diecast aluminium ADC12	Silver • Black / Painted (Unfinished inside)
2	Corner block	2	Diecast aluminium ADC12	Silver • Black / Painted (Unfinished inside)
3	Frame	4	Extruded aluminium A6063S-T5	Silver • Black / Anodized
4	Top cover	1	Aluminium A1100P	Silver • Black / Anodized
5	Bottom cover	1	Aluminium A1100P	Silver • Black / Anodized
6	Rubber feet	4	Synthetic rubber	Black

To select Screw and Color, follow steps **1** ~ **2** below to determine product number.

1 Screw

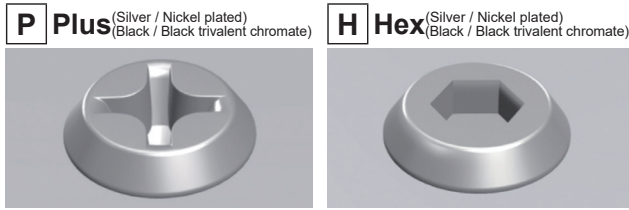

*Color of screw will be the same as top • bottom cover color.

Hex wrench included.

2 Color

Please choose from the color combinations listed below.

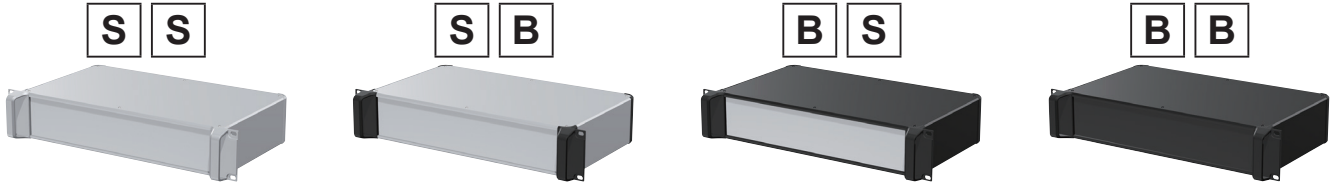

Product Number

To determine a product number, fill H-W-D dimensions and select Screw and Color code in the following blank boxes.

AUXR - - -

H-W-D dimensions **Screw** **Color**
 See below for dimensions / product no. (P or H) (SS • SB • BS • BB)

Numbering example : If looking at "H88 x W430 x D250mm, Screw type H, Color type BS"

➔ **AUXR 88-43-25 H-BS**

Product no. / Details ■ Please suffix screw and color code at the end of the product number.

Product no.	H	W	D	Weight (kg)
AUXR 44-43-16□-□□	44	430	160	1.6
AUXR 44-43-20□-□□	44	430	200	1.8
AUXR 44-43-25□-□□	44	430	250	2.1
AUXR 44-43-30□-□□	44	430	300	2.4
AUXR 44-43-36□-□□	44	430	360	2.7
AUXR 44-43-43□-□□	44	430	430	3.1
AUXR 44-43-50□-□□	44	430	500	3.5
AUXR 88-43-16□-□□	88	430	160	2.0
AUXR 88-43-20□-□□	88	430	200	2.3
AUXR 88-43-25□-□□	88	430	250	2.6
AUXR 88-43-30□-□□	88	430	300	2.9
AUXR 88-43-36□-□□	88	430	360	3.3
AUXR 88-43-43□-□□	88	430	430	3.7
AUXR 88-43-50□-□□	88	430	500	4.2
AUXR133-43-16□-□□	132.5	430	160	2.6
AUXR133-43-20□-□□	132.5	430	200	2.9
AUXR133-43-25□-□□	132.5	430	250	3.2
AUXR133-43-30□-□□	132.5	430	300	3.6
AUXR133-43-36□-□□	132.5	430	360	4.0
AUXR133-43-43□-□□	132.5	430	430	4.6
AUXR133-43-50□-□□	132.5	430	500	5.1
AUXR177-43-16□-□□	177	430	160	3.0
AUXR177-43-20□-□□	177	430	200	3.4
AUXR177-43-25□-□□	177	430	250	3.8
AUXR177-43-30□-□□	177	430	300	4.2
AUXR177-43-36□-□□	177	430	360	4.6
AUXR177-43-43□-□□	177	430	430	5.2
AUXR177-43-50□-□□	177	430	500	5.7

AUXR dimensions

■ DXF/DWG/PDF/STP drawings available on our website.

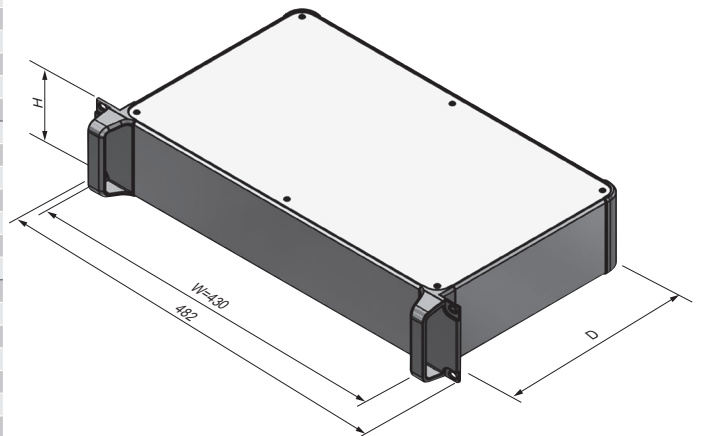

Accessories (Optional parts)

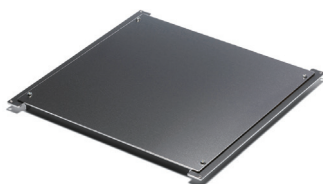

Mounting plate AUC series
See page 179 ~ 180



Rack mounting screw RT series
See page RT • RZ • RW



Rack mounting screw RZ series
See page RT • RZ • RW

RT·RZ series

RACK MOUNTING SCREW

RT



■ Easy installation by built-in washer.

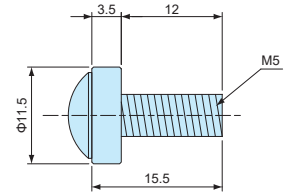

Product no. / Details

Product no.	Material	Finish	Pack of
RT-5S	Steel	Nickel plated	20
RT-5B	Steel	Black trivalent chromate	20

RZ

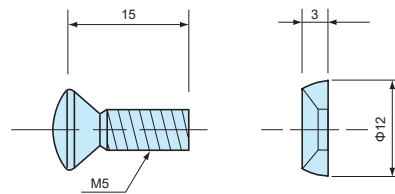

Product no. / Details

1 Round countersunk screw + 2 Decorative washer

Product no.	Material	Color / Finish	Pack of
RZ-5S	Brass	Silver / Nickel plated	20
	Steel screw	Black / Trivalent chromate	
RZ-5B	Brass washer	Semi-gloss black / Painted	20

RW series

RACK MOUNTING SCREW with NYLON WASHER

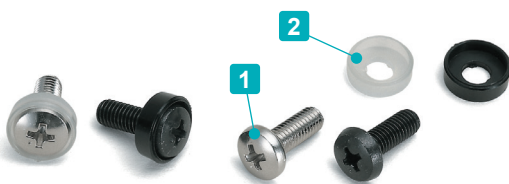

- Nylon washer can protect panel surface when mounting and give anti-loosening effect.
- Black color washer give aesthetical look on panel surface.
- Natural color washer could be faded under long time use.

Components

No.	Part name	Material	Color / Finish
1	Bind screw	Steel	Nickel plated • Black trivalent chromate
2	Nylon washer	Nylon	Black • Natural

Product no. / Details

Product no.	A	B	C	D	M	Screw	Washer	Pack of
RW-3B	7.8	2.5	1.0	6	3	Black trivalent chromate	Black	20
RW-4B	9.8	3.3	1.1	8	4	Black trivalent chromate	Black	20
RW-5B	12	4.0	1.3	14	5	Black trivalent chromate	Black	20
RW-5S	12	4.0	1.3	14	5	Nickel plated	Natural	20

