

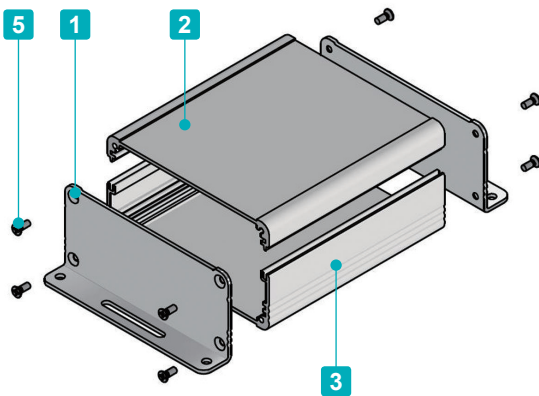

- Selectable in 20 different Width / Height types, with adjustable length (depth) in 1mm intervals from 40 to 500mm.
- Equipped with flanged panel or bracket for easy wall mounting.
- Flanged panel type or flanged bracket type extruded aluminium enclosure.
- Rubber feet are included only on EXFS19-□, 23-□ and 29-□ models.

Flanged panel type EXFS6-□, 8-□, 11-□ and 14-□



Flanged bracket type EXFS19-□, 23-□ and 29-□

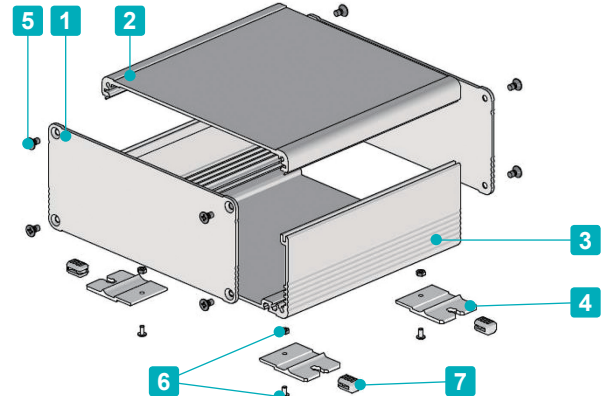

**Components**

No.	Part name	Pcs	Material	Color / Finish
1	Flanged panel (EXFS 61-□, 81-□, 106-□ and 141-□) Panel (EXFS 187-□, 232-□, and 288-□)	2	Aluminium A1050P	Silver • Black / Anodized
2	Top cover	1	Extruded aluminium A6063S-T5	Silver • Black / Anodized with clear coating
3	Bottom cover	1	Extruded aluminium A6063S-T5	Silver • Black / Anodized with clear coating
4	Flange bracket (only for EXFS 187-□, 232-□, and 288-□)	4	Extruded aluminium A6063S-T5	Metallic silver / Painted
5	Panel screw (Phillips head)	8	Stainless steel	Unfinished
6	Flange screw (EXFS 187-□, 232-□, and 288-□)	4 each	Steel	Black trivalent chromate
7	Rubber feet (EXFS 187-□, 232-□, and 288-□)	8	Silicone	Black

■ See page EXFS-5 to 8 for Top / Bottom cover dimensions.

**Product Number**

To determine a product number, fill W-H, D length and select Color code in the following blank boxes.

Product no.    EXFS        -       

**1** W-H                      **1** D length                      **2** Color code

Numbering example: W-H:106-48 x D:123 and SB color code → EXPFS106-48-123SB

EXFS        -

# 1 Dimensions

To select W-H dimensions from the table below, and D length in 1mm intervals.

## Width-Height dimensions

Flanged panel type EXFS61-□, 81-□, 106-□ and 141-□

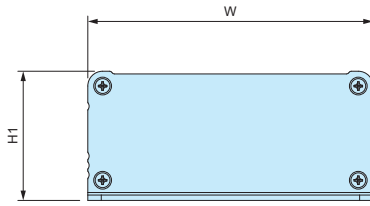

Flanged bracket type EXFS187-□, 232-□ and 288-□

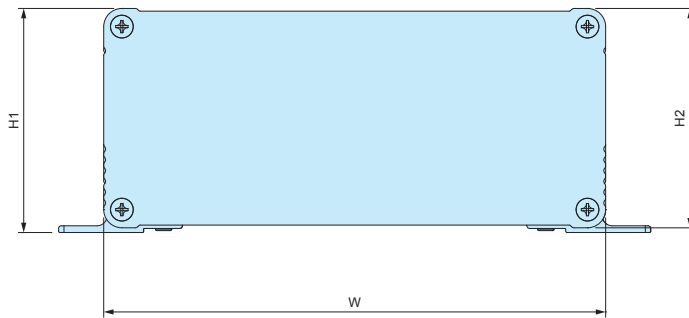

W-H No.	W	H1	H2
61- 28	60.6	27.6	-
61- 38	60.6	37.6	-
61- 53	60.6	52.6	-
81- 33	80.6	32.6	-
81- 43	80.6	42.6	-
81- 58	80.6	57.6	-
106- 33	106	33	-
106- 48	106	48	-
106- 63	106	63	-
141- 38	141	38	-
141- 53	141	53	-
141- 73	141	73	-
141- 93	141	93	-
187- 44	186.5	45.25	43.5
187- 62	186.5	63.25	61.5
187- 82	186.5	83.25	81.5
187-107	186.5	108.25	106.5
232- 52	232	53.5	52
232- 77	232	78.5	77
232-102	232	103.5	102
288- 78	287.5	78.75	77.5
288-128	287.5	128.75	127.5

## D length

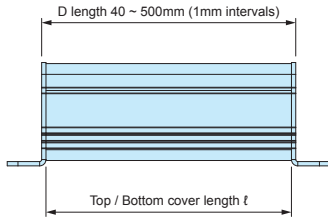

Flanged panel type  
EXFS 61-□, 81-□, 106-□ and 141-□

W-H No.	ℓ
61-□	D-4
81-□	D-4
106-□	D-4
141-□	D-4
187-□	D-5
232-□	D-6
288-□	D-6

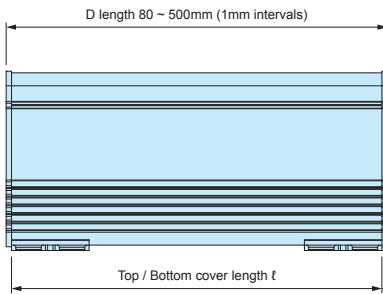

Flanged bracket type  
EXFS 187-□, 232-□ and 288-□

■ D length can be requested in 0.1mm intervals, but with higher tolerances (±0.3mm).

■ See page EXFS-3 detailed dimensions.

# 2 Color

To select color code from the table below.

\*For flange bracket models, color will be the same as top • bottom cover.

Code	S S Silver / Silver	S B Silver / Black	B S Black / Silver	B B Black / Black
Color				

## Lead Time

Custom Size Only  
Custom Size + Hole Milling

4 business days (1 ~ 5 pcs)  
9 business days (1 ~ 5 pcs)

## Order Inquiry

For more information, contact us here at [sales@takachi-el.co.jp](mailto:sales@takachi-el.co.jp).

**EXFS Dimensions**

■ DXF/DWG/PDF drawings available on our website.

Flanged panel type EXFS61-□, 81-□, 106-□ and 141-□

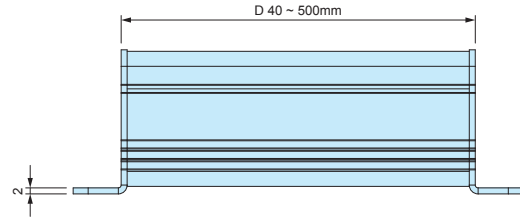
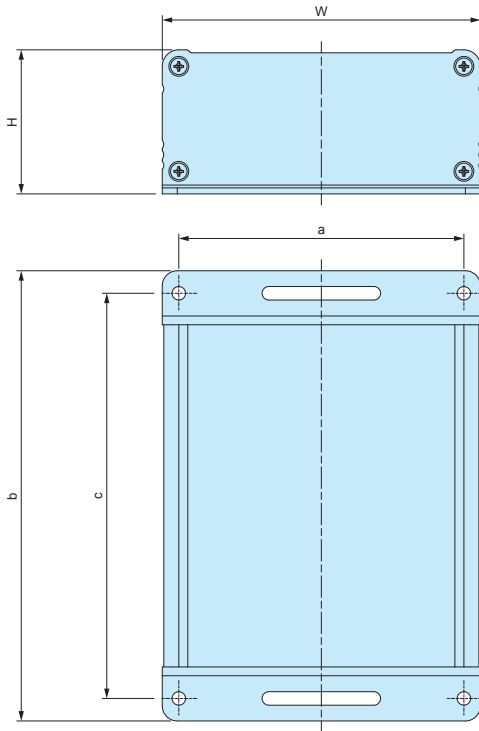

Product no.	W	H	a	b	c
EXFS 61-28-□	60.6	27.6	52	D+28	D+16
EXFS 61-38-□	60.6	37.6	52	D+28	D+16
EXFS 61-53-□	60.6	52.6	52	D+28	D+16
EXFS 81-33-□	80.6	32.6	72	D+32	D+20
EXFS 81-43-□	80.6	42.6	72	D+32	D+20
EXFS 81-58-□	80.6	57.6	72	D+32	D+20
EXFS106-33-□	106	33	95	D+32	D+17
EXFS106-48-□	106	48	95	D+32	D+17
EXFS106-63-□	106	63	95	D+32	D+17
EXFS141-38-□	141	38	130	D+32	D+17
EXFS141-53-□	141	53	130	D+32	D+17
EXFS141-73-□	141	73	130	D+32	D+17
EXFS141-93-□	141	93	130	D+32	D+17

Flanged bracket type EXFS187-□, 232-□ and 288-□

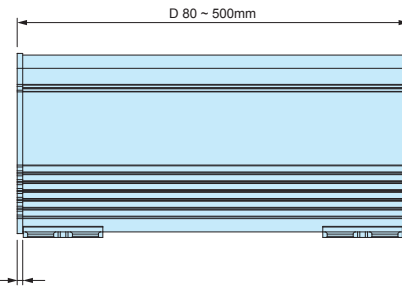
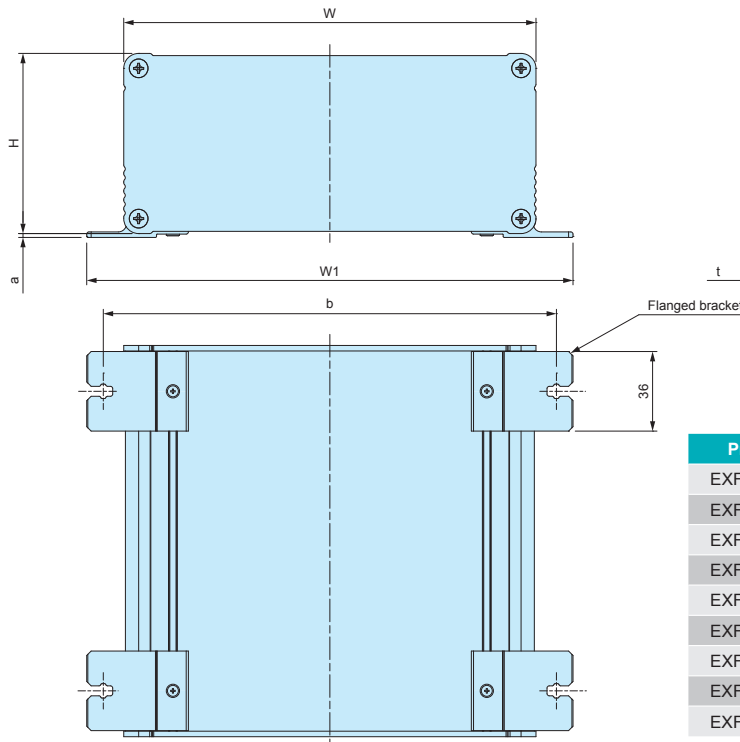

Product no.	W	W1	H	a	b	t
EXFS187- 44-□	186.5	220	43.5	1.75	205	2.5
EXFS187- 62-□	186.5	220	61.5	1.75	205	2.5
EXFS187- 82-□	186.5	220	81.5	1.75	205	2.5
EXFS187-107-□	186.5	220	106.5	1.75	205	2.5
EXFS232- 52-□	232	265	52	1.5	250	3
EXFS232- 77-□	232	265	77	1.5	250	3
EXFS232-102-□	232	265	102	1.5	250	3
EXFS288- 78-□	287.5	320	77.5	1.25	305	3
EXFS288-128-□	287.5	320	127.5	1.25	305	3

**Accessories (Optional parts)**



Rubber strain relief cord protector CBS series  
See page CBS

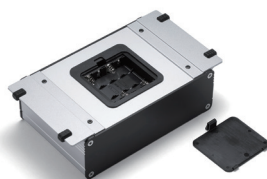

Embedded battery box BC series  
See page 125 ~ 128

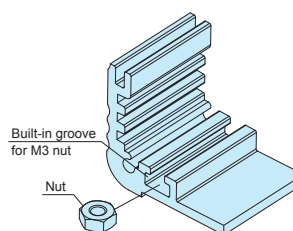

Sliding nut for EXF • EXFS MT-3N  
See page EXF • EXFS-4



Insert nut adhesive standoff AST series  
See page 121



- Flanged panel type or flanged bracket type extruded aluminium enclosure.
- Equipped with flanged panel or bracket for easy wall mounting.
- Anodized finish with clear coating (except for flanged bracket) and selectable in 4 different color combinations.
- Rubber feet are included only on EXF19-□, 23-□ and 29-□ models.

Flanged panel type EXF6-□, 8-□, 11-□ and 14-□

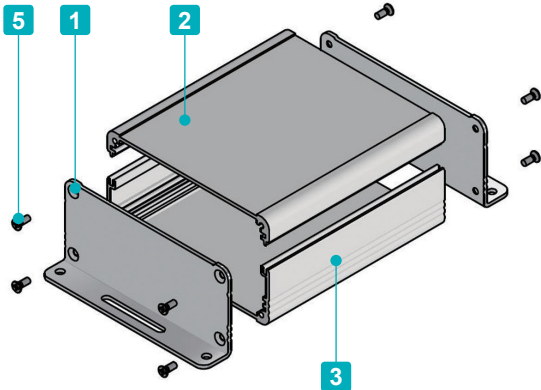

Flanged bracket type EXF19-□, 23-□ and 29-□

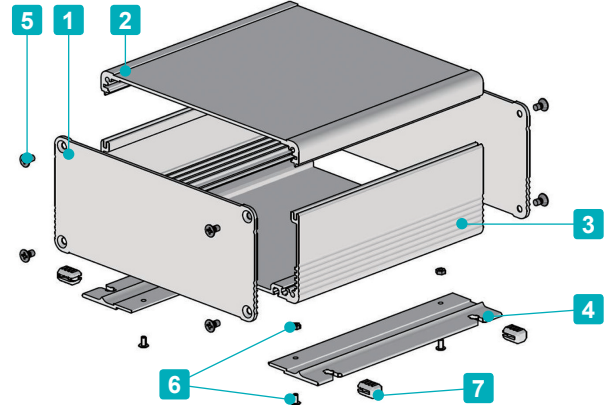

**Components**

No.	Part name	Pcs	Material	Color / Finish
1	Flanged panel (EXHF8-□, 11-□, 14-□) Panel (EXHF19-□, 23-□, 29-□)	2	Aluminium A1050P	Silver • Black / Anodized
2	Top cover	1	Extruded aluminium A6063S-T5	Silver • Black / Anodized with clear coating
3	Bottom cover	1	Extruded aluminium A6063S-T5	Silver • Black / Anodized with clear coating
4	Flange bracket (only for EXF19-□, 23-□, and 29-□)	2	Extruded aluminium A6063S-T5	Metallic silver / Painted • Black / Anodized
5	Panel screw (Phillips head)	8	Stainless steel	Unfinished
6	Flange screw / nut (only for EXF19-□, 23-□, and 29-□)	4 each	Steel	Black trivalent chromate
7	Rubber feet (only for EXF19-□, 23-□, and 29-□)	4	Silicone	Black

■ See page EXFS-5 to 8 for Top / Bottom cover dimensions.

**Color Type** \*For flange bracket models, color will be the same as top • bottom cover.

Code	SS Silver / Silver	SB Silver / Black	BS Black/Silver	BB Black/Black
Color				

■ DXF/DWG/PDF/STP drawings available on our website.

Flanged panel type EXF6-□, 8-□, 11-□ and 14-□

Flanged bracket type EXF19-□, 23-□ and 29-□

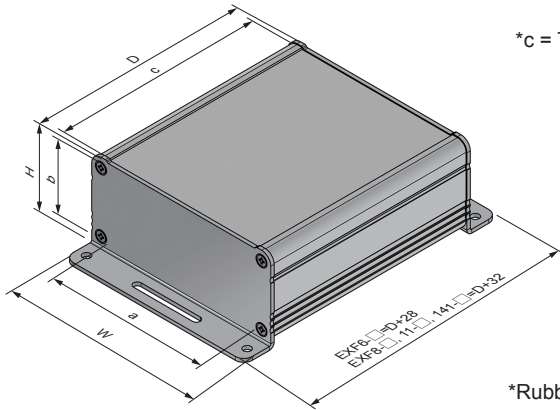

\*c = Top/Bottom covers length.

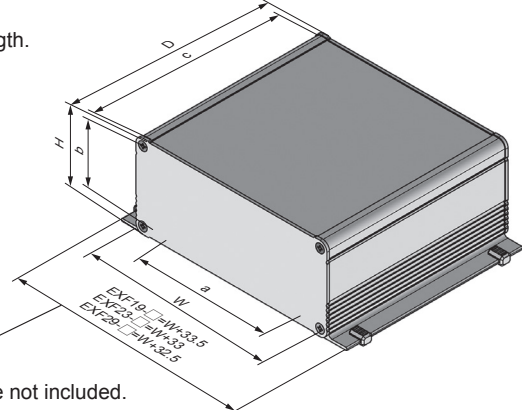

\*Rubber feet dimensions are not included.

- Included screws  
 EXF 6-□ and 8-□ models : M2.5-8 x 8 pcs    EXF11-□, 14-□ models : M3-8 x 8 pcs  
 EXF19-□ models : M4-10 x 8 pcs    EXF23-□, 29-□ models : M5-10 x 8 pcs

Product no. / Details

■ Please suffix color code at the end of the product number.

Product no.	External dimensions			Internal dimensions			Weight (g)
	W	H	D	a	b	c	
EXF 6-3- 5□□	60.6	27.6	50	46	19.6	46	63
EXF 6-3- 8□□	60.6	27.6	77	46	19.6	73	85
EXF 6-3-10□□	60.6	27.6	100	46	19.6	96	105
EXF 6-4- 5□□	60.6	37.6	50	46	29.6	46	75
EXF 6-4- 8□□	60.6	37.6	77	46	29.6	73	101
EXF 6-4-10□□	60.6	37.6	100	46	29.6	96	124
EXF 6-5- 5□□	60.6	52.6	50	46	44.6	46	92
EXF 6-5- 8□□	60.6	52.6	77	46	44.6	73	122
EXF 6-5-10□□	60.6	52.6	100	46	44.6	96	148
EXF 8-3- 6□□	80.6	32.6	60	66	24.6	56	106
EXF 8-3- 9□□	80.6	32.6	90	66	24.6	86	143
EXF 8-3-12□□	80.6	32.6	120	66	24.6	116	180
EXF 8-4- 6□□	80.6	42.6	60	66	34.6	56	122
EXF 8-4- 9□□	80.6	42.6	90	66	34.6	86	162
EXF 8-4-12□□	80.6	42.6	120	66	34.6	116	203
EXF 8-6- 6□□	80.6	57.6	60	66	49.6	56	145
EXF 8-6- 9□□	80.6	57.6	90	66	49.6	86	189
EXF 8-6-12□□	80.6	57.6	120	66	49.6	116	234
EXF11-3- 8□□	106	33	78	88	24	74	177
EXF11-3-12□□	106	33	118	88	24	114	244
EXF11-3-16□□	106	33	164	88	24	160	322
EXF11-5- 8□□	106	48	78	88	39	74	206
EXF11-5-12□□	106	48	118	88	39	114	279
EXF11-5-16□□	106	48	164	88	39	160	364
EXF11-6- 8□□	106	63	78	88	54	74	238
EXF11-6-12□□	106	63	118	88	54	114	319
EXF11-6-16□□	106	63	164	88	54	160	412
EXF14-4-10□□	141	38	97	106.8	29	93	287
EXF14-4-14□□	141	38	137	106.8	29	133	377
EXF14-4-19□□	141	38	187	106.8	29	183	491
EXF14-5-10□□	141	53	97	106.8	44	93	325
EXF14-5-14□□	141	53	137	106.8	44	133	422
EXF14-5-19□□	141	53	187	106.8	44	183	544
EXF14-7-10□□	141	73	97	106.8	64	93	371
EXF14-7-14□□	141	73	137	106.8	64	133	475
EXF14-7-19□□	141	73	187	106.8	64	183	606
EXF14-9-10□□	141	93	97	106.8	84	93	422
EXF14-9-14□□	141	93	137	106.8	84	133	536
EXF14-9-19□□	141	93	187	106.8	84	183	679

Product no.	External dimensions			Internal dimensions			Weight (g)
	W	H	D	a	b	c	
EXF19- 4-13□□	186.5	45.25	125	131	35	120	652
EXF19- 4-18□□	186.5	45.25	177	131	35	172	875
EXF19- 4-23□□	186.5	45.25	230	131	35	225	1,101
EXF19- 4-29□□	186.5	45.25	285	131	35	280	1,333
EXF19- 6-13□□	186.5	63.25	125	131	53	120	722
EXF19- 6-18□□	186.5	63.25	177	131	53	172	959
EXF19- 6-23□□	186.5	63.25	230	131	53	225	1,195
EXF19- 6-29□□	186.5	63.25	285	131	53	280	1,444
EXF19- 8-13□□	186.5	83.25	125	131	73	120	802
EXF19- 8-18□□	186.5	83.25	177	131	73	172	1,059
EXF19- 8-23□□	186.5	83.25	230	131	73	225	1,311
EXF19- 8-29□□	186.5	83.25	285	131	73	280	1,576
EXF19-11-13□□	186.5	108.25	125	131	98	120	926
EXF19-11-18□□	186.5	108.25	177	131	98	172	1,184
EXF19-11-23□□	186.5	108.25	230	131	98	225	1,463
EXF19-11-29□□	186.5	108.25	285	131	98	280	1,739
EXF23- 5-15□□	232	53.5	153	176	43	147	1,024
EXF23- 5-21□□	232	53.5	213	176	43	207	1,350
EXF23- 5-27□□	232	53.5	273	176	43	267	1,682
EXF23- 5-33□□	232	53.5	333	176	43	327	2,012
EXF23- 8-15□□	232	78.5	153	176	68	147	1,164
EXF23- 8-21□□	232	78.5	213	176	68	207	1,509
EXF23- 8-27□□	232	78.5	273	176	68	267	1,854
EXF23- 8-33□□	232	78.5	333	176	68	327	2,225
EXF23-10-15□□	232	103.5	153	176	93	147	1,303
EXF23-10-21□□	232	103.5	213	176	93	207	1,682
EXF23-10-27□□	232	103.5	273	176	93	267	2,060
EXF23-10-33□□	232	103.5	333	176	93	327	2,455
EXF29- 8-23□□	287.5	78.75	234	230	68	228	1,893
EXF29- 8-30□□	287.5	78.75	304	230	68	298	2,361
EXF29- 8-38□□	287.5	78.75	384	230	68	378	2,896
EXF29-13-23□□	287.5	128.75	234	230	118	228	2,305
EXF29-13-30□□	287.5	128.75	304	230	118	298	2,832
EXF29-13-38□□	287.5	128.75	384	230	118	378	3,433

- Grooves for M3 sliding nut are built into the top and bottom covers (140mm or wider).  
Optional nut is available.

- Flange bracket is installed as per the diagram below.

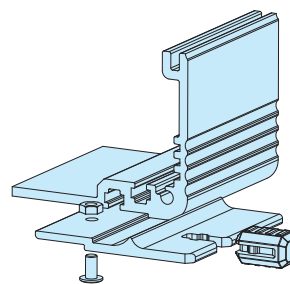
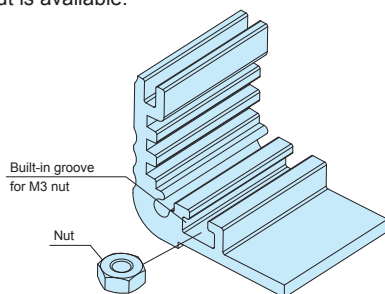

Cross-section view of top & bottom covers

EXF 6-3-□  
EXFS 61-28-□

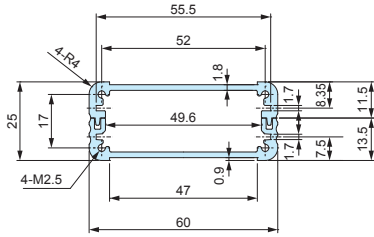

EXF 6-4-□  
EXFS 61-38-□

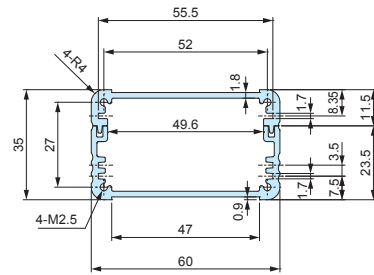

EXF 6-5-□  
EXFS 61-53-□

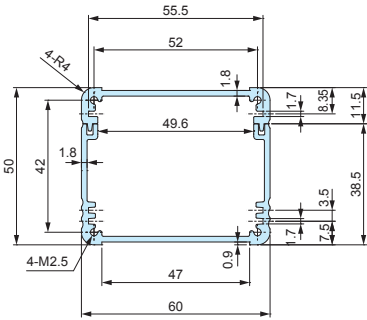

EXF 8-3-□  
EXFS 81-33-□

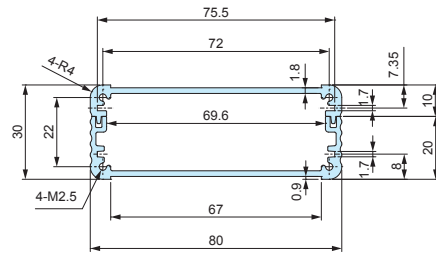

EXF 8-4-□  
EXFS 81-43-□

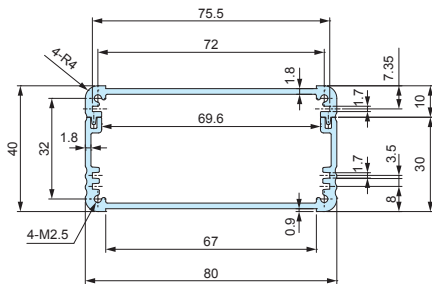

EXF 8-6-□  
EXFS 81-58-□

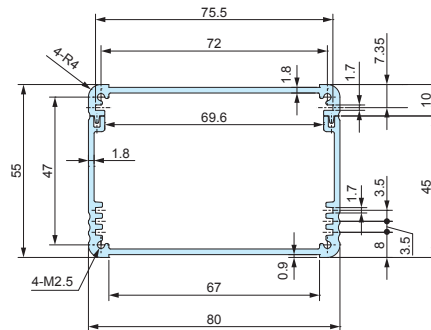

EXF 11-3-□  
EXFS 106-33-□

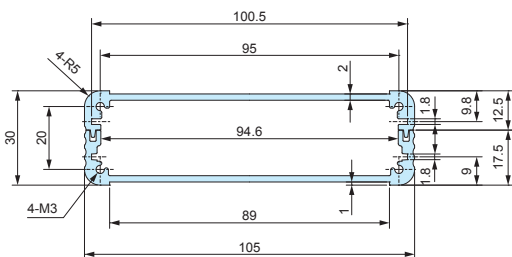

EXF 11-5-□  
EXFS 106-48-□

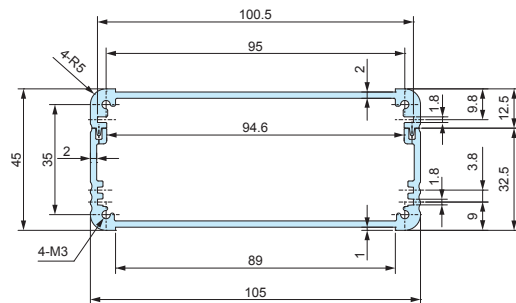

EXF 11-6-□  
EXFS 106-63-□

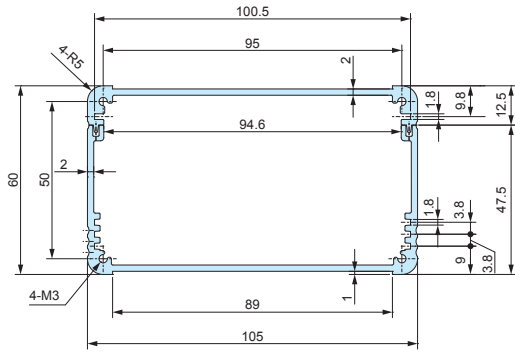

EXF 14-4-□  
EXFS 141-38-□

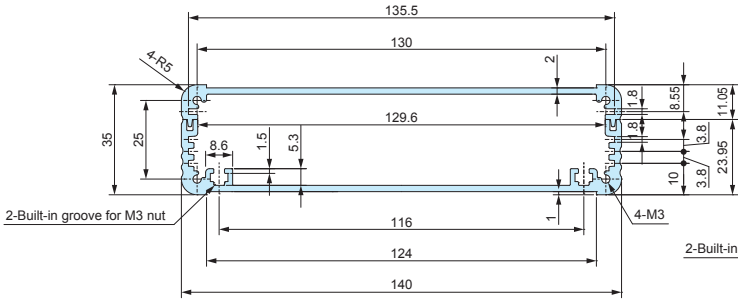

EXF 14-5-□  
EXFS 141-53-□

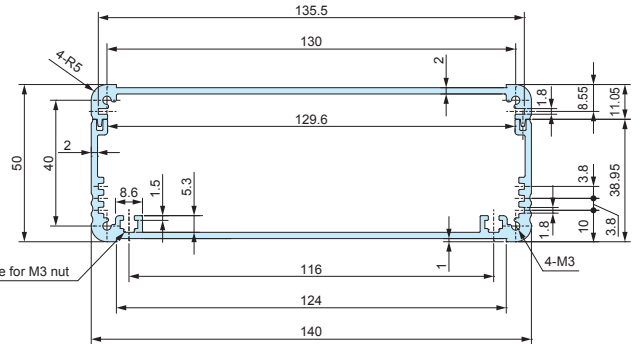

EXF 14-7-□  
EXFS 141-73-□

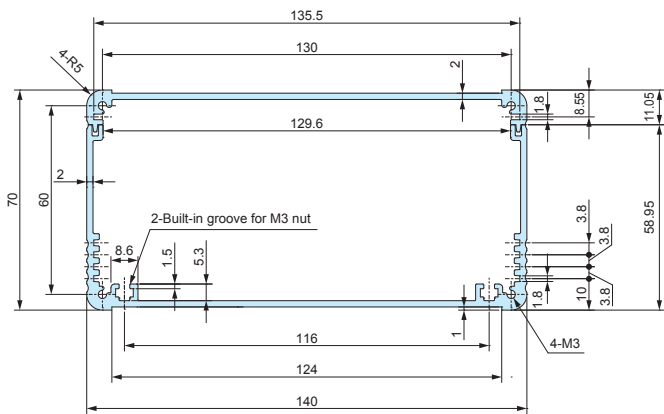

EXF 14-9-□  
EXFS 141-93-□

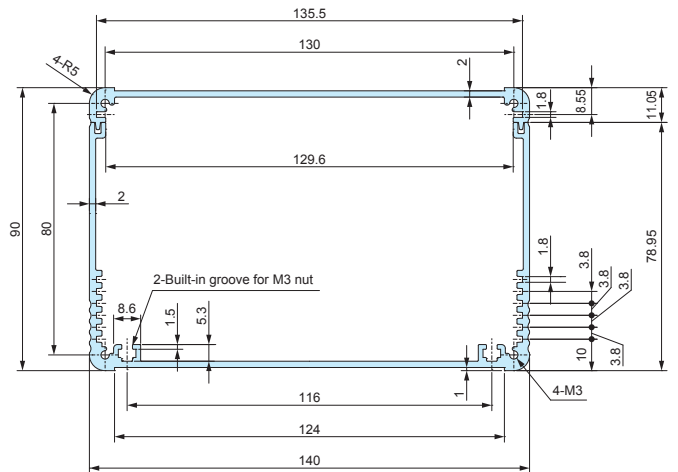

- Grooves for M3 sliding nut are built into the top and bottom covers (140mm or wider). Optional nut is available.

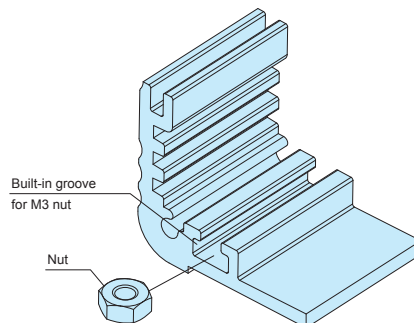

EXF 19-4-□  
EXFS 187-44-□

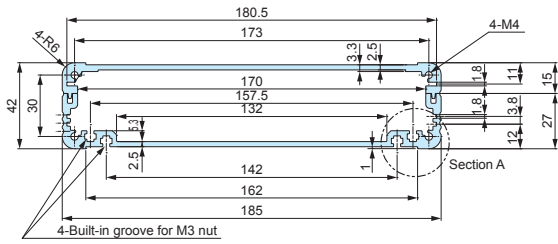

EXF 19-6-□  
EXFS 187-62-□

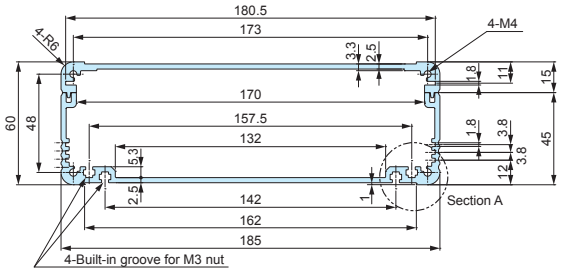

EXF 19-8-□  
EXFS 187-82-□

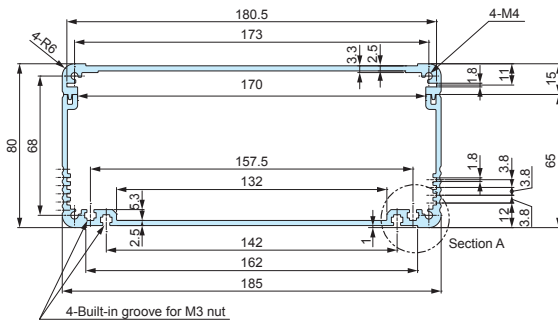

EXF 19-11-□  
EXFS 187-107-□

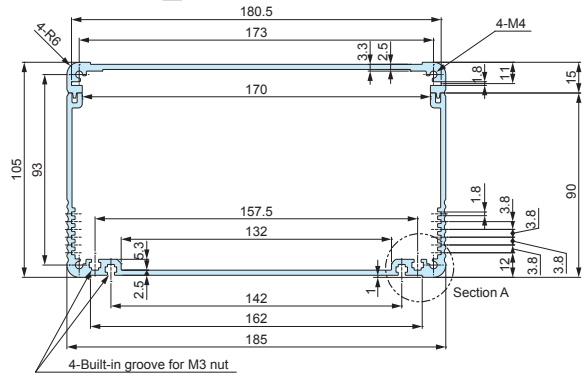

EXF 23-5-□  
EXFS 232-52-□

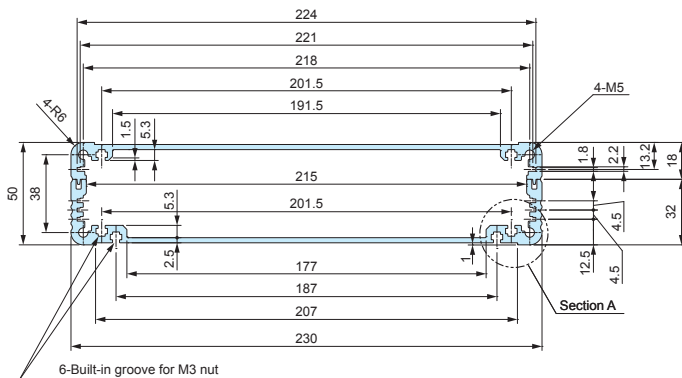

EXF 23-8-□  
EXFS 232-77-□

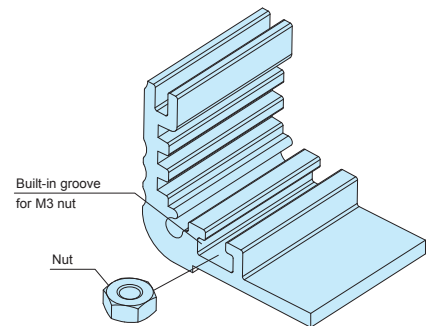
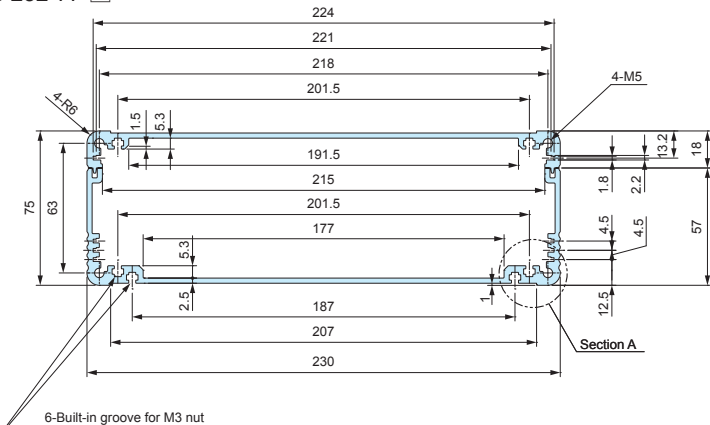

- Grooves for M3 sliding nut are built into the top and bottom covers (140mm or wider). Optional nut is available.

\*See EXFS-8 for section A dimension of larger than EXF-19-4-□ and EXFS188-44-□



EXF 23-10-□  
EXFS 232-102-□

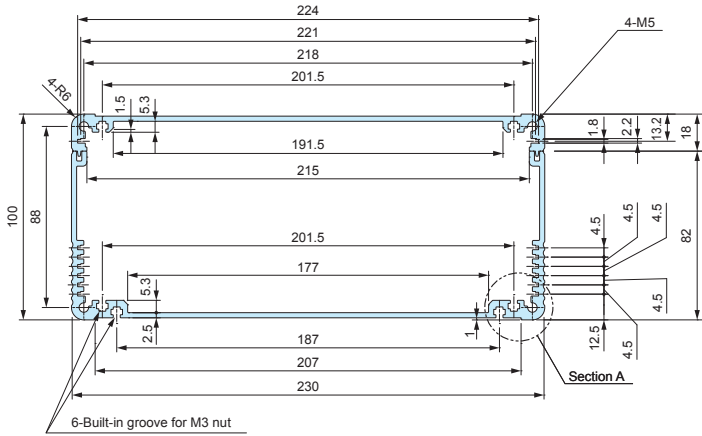

EXF 29-8-□  
EXFS 288-78-□

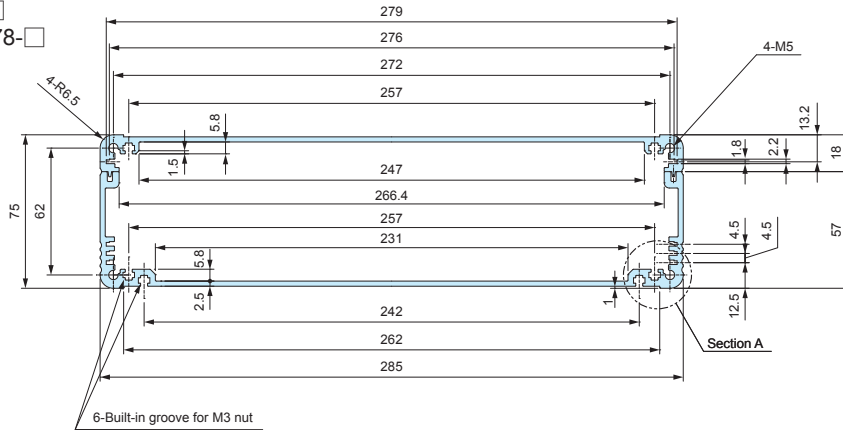

EXF 29-13-□  
EXFS 288-128-□

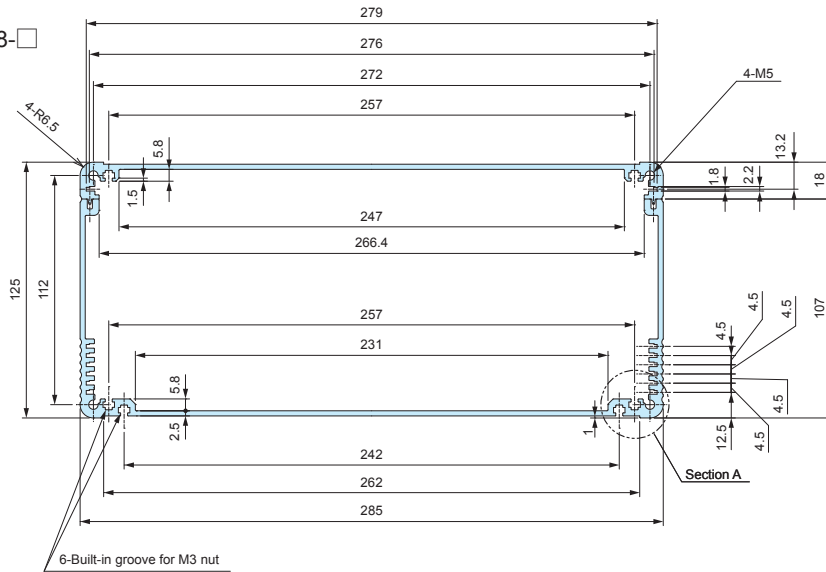

EXF • EXFS series  
Flange bracket dimensions  
(Section A)

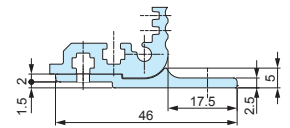

Accessories (Optional parts)

MT-3N

SLIDING NUT for EXF • EXFS

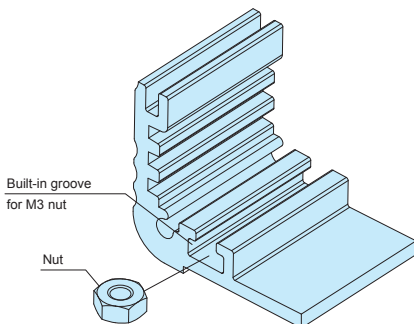

MT-3N dimensions

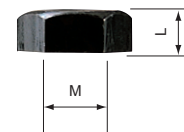

Product no. / Dimensions

Product no.	M	L	Material	Finish	Pack of
MT-3N	3	2.4	Steel	Black trivalent chromate	50

- Sliding nut can be used on all EXF • EXFS models with width 140 mm or larger bottom covers.



Technical Data

Operating temperature: -10°C ~ +60°C

Mount Example

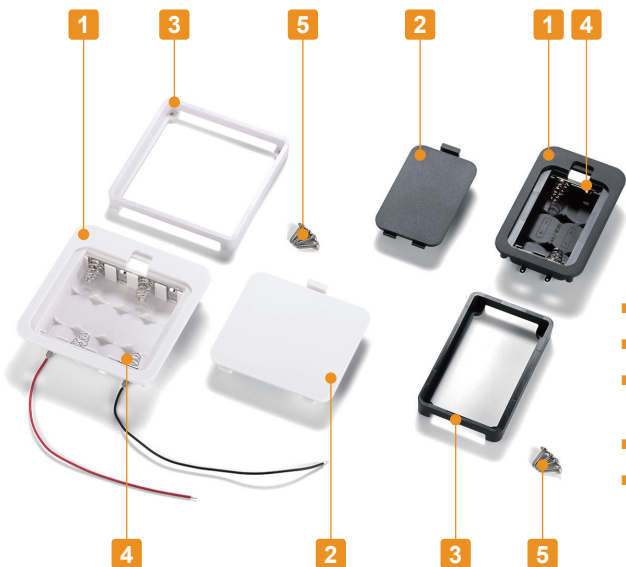

- Suitable to be installed into enclosures with material thickness of 1.0mm to 3.5mm.
- Cover can be opened/closed without any tool for easy battery replacement.
- 5 different battery layouts are available as AA x 2, AA x 3, AA x 4, AAA x 2 and AAA x 4. Each layout comes in 2 models: with lead-wire, and without lead-wire.
- ⊕ ⊖ markings prevents incorrect placement of battery.
- The dimensions of alkaline or manganese batteries may vary depending on country and brand. Use optional battery cushion sponge to preventing rattling.

Components

No.	Part name	Pcs	Material	Color / Finish
1	Box	1	ABS UL94V-0	Black • Off-white
2	Cover	1	ABS UL94V-0	Black • Off-white
3	Frame	1	ABS UL94V-0	Black • Off-white
4	Battery contact Lead wire (BC-L models)	1 set	Battery contact : Brass & steel wire Lead wire : PVC + Copper wire (UL1007 AWG26)	Nickel plated Black • Red
5	Self-tapping screw	4	Steel	Nickel plated

**BC dimensions**

- DXF/DWG/PDF/STP drawings available on our website.
- The shape and position of battery contacts vary by models.

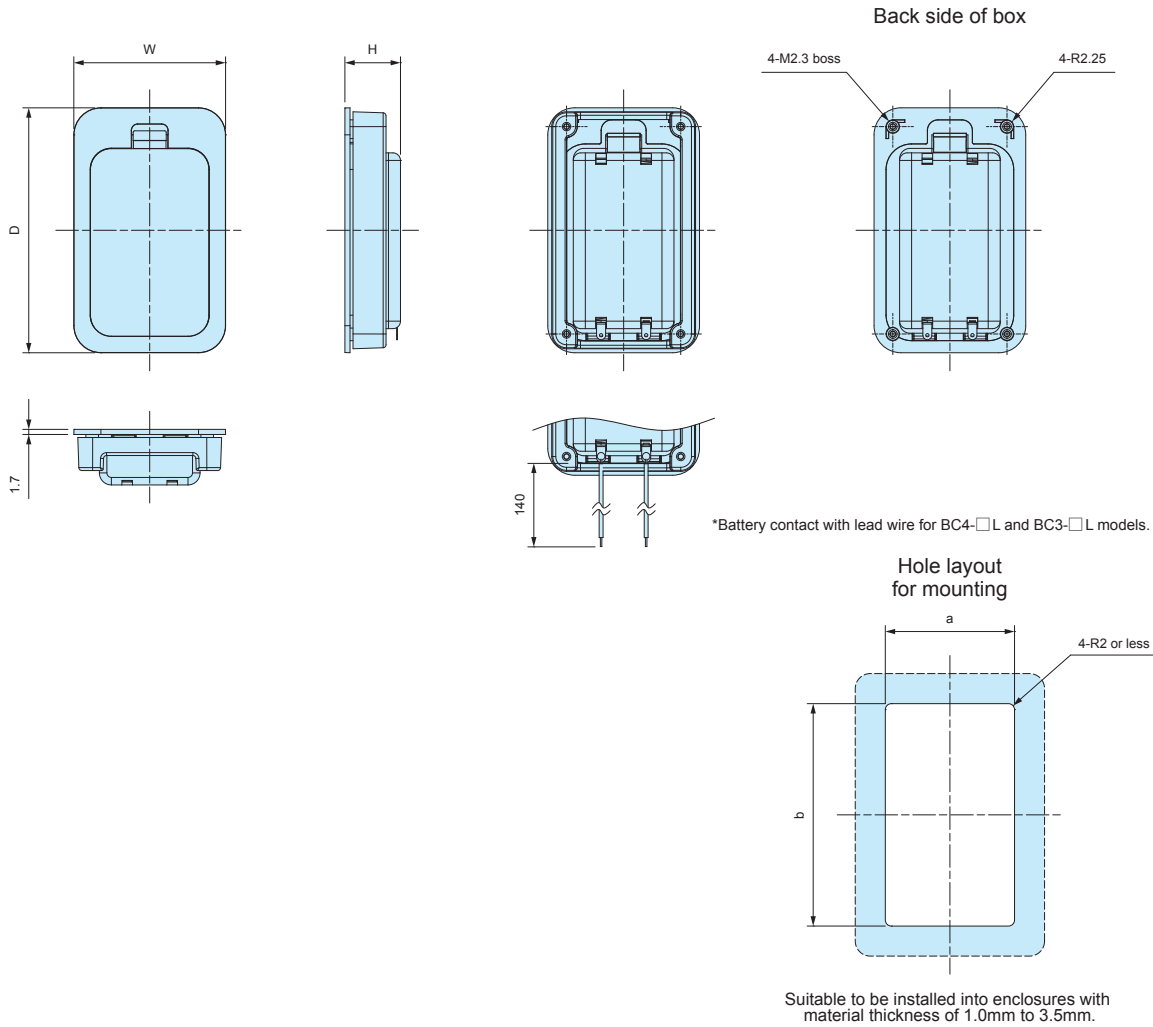

**Type: Without Lead Wire**

**Product no. / Dimensions**

Product no.		Dimensions					Battery layout	Weight (g)
● Black	● Off-white	W	H	D	a	b		
BC4-2-B	BC4-2-W	40	14.8	78.5	32.5	71	*AAA x 2	24.5
BC4-4-B	BC4-4-W	62	14.8	78.5	54.5	71	*AAA x 4	34.5
BC3-2-B	BC3-2-W	50.5	18.5	81.5	43	74	*AA x 2	31.5
BC3-3-B	BC3-3-W	65.5	18.5	81.5	58	74	*AA x 3	39
BC3-4-B	BC3-4-W	80.5	18.5	81.5	73	74	*AA x 4	46

\*Alkaline or manganese batteries

**Type: With Lead Wire**

**Product no. / Dimensions**

Product no.		Dimensions					Battery layout	Weight (g)
● Black	● Off-white	W	H	D	a	b		
BC4-2L-B	BC4-2L-W	40	14.8	78.5	32.5	71	*AAA x 2	25.5
BC4-4L-B	BC4-4L-W	62	14.8	78.5	54.5	71	*AAA x 4	35.5
BC3-2L-B	BC3-2L-W	50.5	18.5	81.5	43	74	*AA x 2	32.5
BC3-3L-B	BC3-3L-W	65.5	18.5	81.5	58	74	*AA x 3	40
BC3-4L-B	BC3-4L-W	80.5	18.5	81.5	73	74	*AA x 4	47

\*Alkaline or manganese batteries

# How to mount on the enclosures

■ Insert battery box into the milled hole first, and fit the frame on the back side. Once mounted, secure the frame with screws.

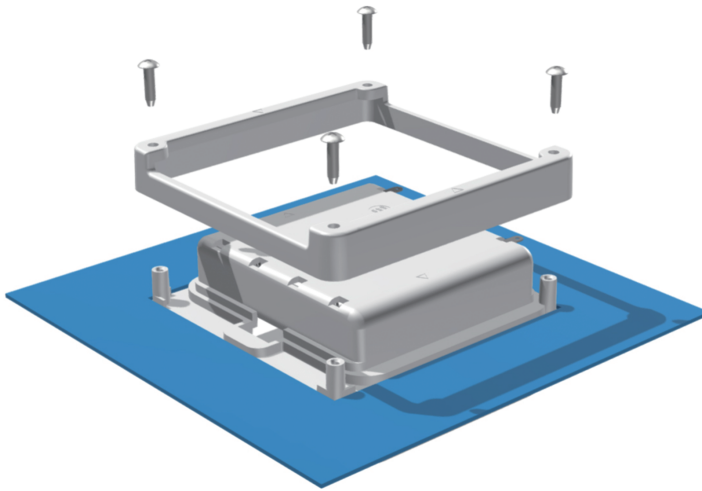

■ For BC3-4□ models, ▷ markings are shown on the frame. Install by matching the markings.

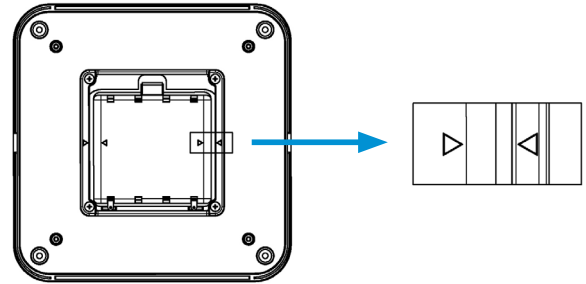

## Parallel circuit conversion on BC series battery box

- BC-3□ models can be converted from a series to a parallel circuit. See below illustration for further details.
- IT series (IT-3 models) optional battery contacts can be used for parallel circuit conversion. (See website for more information)
- Use caution when installing or replacing the terminals to avoid the damage to the material.
- Parallel series conversion is available via our customization services.

## Conversion Example

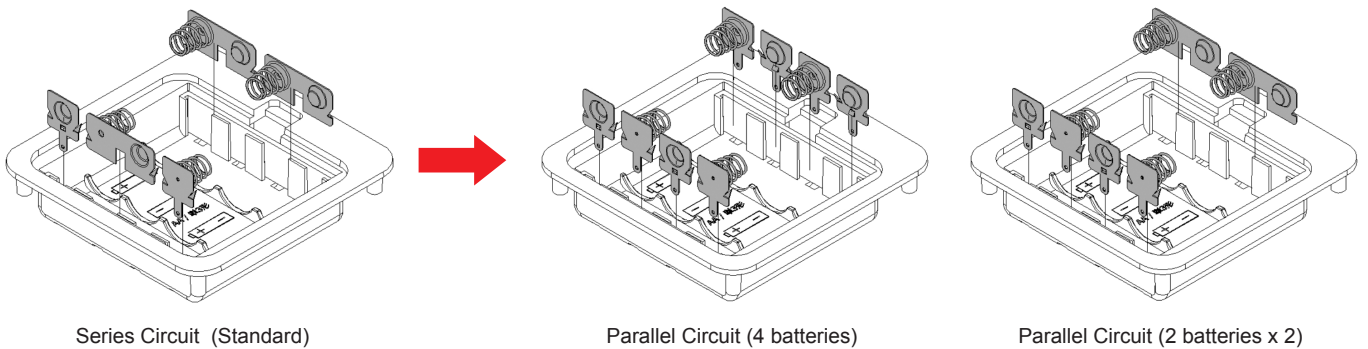

Series Circuit (Standard)

Parallel Circuit (4 batteries)

Parallel Circuit (2 batteries x 2)

### Customization Available

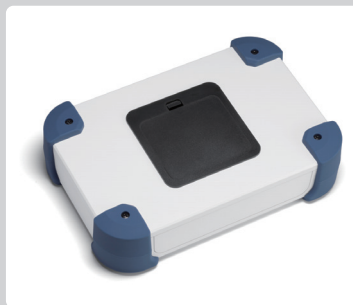

For more information, contact us here:

Online form: [https://www.takachi-enclosure.com/custom/form\\_custom](https://www.takachi-enclosure.com/custom/form_custom)  
 E-mail : [sales@takachi-el.co.jp](mailto:sales@takachi-el.co.jp)



# Mount Example



■ BC series battery boxes can also be mounted on aluminium enclosures.



**Application example**



Installed onto SIC series



Installed onto EX series

- 4 new sizes added for a total of 8 different sizes available for selection.
- Strain relief cord protector help relief flex stress and damage to cables.
  - ※ Does not prevent cables from being dislodged.
- 2 types - round and flat - are available.
- Insert from the inner side of the case / panel of the enclosure.
- Made from high heat resistant silicone material.

Technical Data
Operating temperature: -40°C ~ +100°C

**Installation steps**

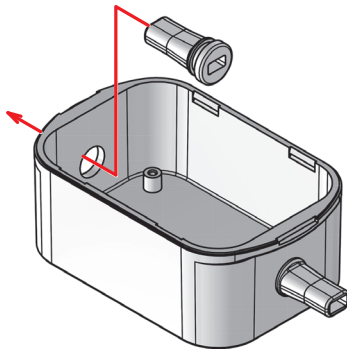

- ① Insert into the mounting hole from the inside.
  - ② Thread the cable through the protector.
- ※ Protector must be installed first.

**CBS dimensions**

■ DXF/DWG/PDF drawings available on our website.

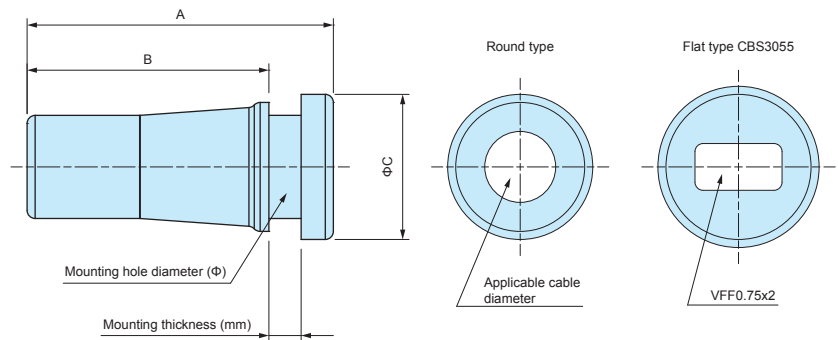

**Product no. / Details**

Product no.		A	B	C	Applicable cable diameter / type	Mounting hole diameter (Φ)	Mounting thickness (mm)	Material	Pack of
● Black	● Off-white								
<b>NEW</b> CBS3055-15B	<b>NEW</b> CBS3055-15W	18.5	15	10	VFF0.75x2	7.6 ~ 7.8	1.5 ~ 2.0	Silicone	10
CBS3055-20B	CBS3055-20W	19	15	10	VFF0.75x2	7.6 ~ 7.8	2.0 ~ 2.5	Silicone	10
<b>NEW</b> CBS35-15B	<b>NEW</b> CBS35-15W	16.5	13	8	Φ3.5	5.6 ~ 5.8	1.5 ~ 2.0	Silicone	10
CBS35-20B	CBS35-20W	17	13	8	Φ3.5	5.6 ~ 5.8	2.0 ~ 2.5	Silicone	10
<b>NEW</b> CBS45-15B	<b>NEW</b> CBS45-15W	18.5	15	9	Φ4.5	6.6 ~ 6.8	1.5 ~ 2.0	Silicone	10
CBS45-20B	CBS45-20W	19	15	9	Φ4.5	6.6 ~ 6.8	2.0 ~ 2.5	Silicone	10
<b>NEW</b> CBS60-15B	<b>NEW</b> CBS60-15W	20.5	17	10.5	Φ6.0	8.1 ~ 8.3	1.5 ~ 2.0	Silicone	10
CBS60-20B	CBS60-20W	21	17	10.5	Φ6.0	8.1 ~ 8.3	2.0 ~ 2.5	Silicone	10

**AST** series

**INSERT NUT ADHESIVE STANDOFF**



- Double-sided adhesive tape allows the standoff to be mounted quickly and easily; allows PCB mounting in non-boss enclosures.
- Convenient for installing PCBs into enclosures without the need for customization.
- Please ensure that surface is cleaned and grease-free before adhering.
- Once removed, it cannot be adhered on again.

**AST dimensions**

■ DXF/DWG/PDF/STP drawings available on our website.

AST2.5-□

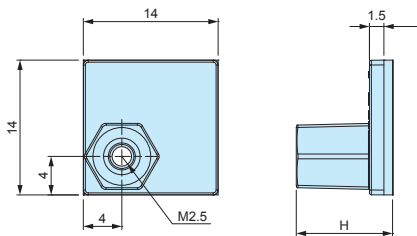

AST3-□

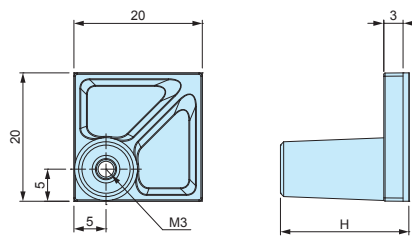

AST4-□

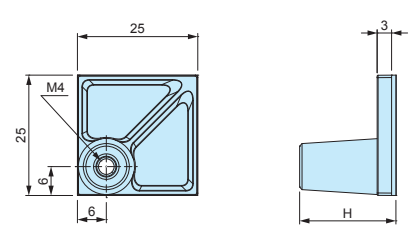

**Product no. / Dimensions**

**Bulk package**

Product no	H dimension	Included screw	Recommended PCB Thickness (mm)	Recommended torque (N · m)	Weight (g)	Pack of	Product no	Pack of
AST2.5-5B	5	M2.5-5 pan head	1.0 ~ 2.0	0.3	0.6 (1 piece)	4	AST2.5-5B-P	100
AST2.5-10B	10	M2.5-5 pan head	1.0 ~ 2.0	0.3	0.8 (1 piece)	4	AST2.5-10B-P	100
AST3-6B	6	M3-6 pan head	1.0 ~ 3.0	0.4	1.5 (1 piece)	4	AST3-6B-P	100
AST3-10B	10	M3-6 pan head	1.0 ~ 3.0	0.4	1.6 (1 piece)	4	AST3-10B-P	100
AST3-15B	15	M3-6 pan head	1.0 ~ 3.0	0.4	1.8 (1 piece)	4	AST3-15B-P	100
AST3-20B	20	M3-6 pan head	1.0 ~ 3.0	0.4	2.1 (1 piece)	4	AST3-20B-P	100
AST4-10.5B	10.5	M4-8 pan head	1.0 ~ 3.5	0.8	2.6 (1 piece)	4	AST4-10.5B-P	50
AST4-20B	20	M4-8 pan head	1.0 ~ 3.5	0.8	3.2 (1 piece)	4	AST4-20B-P	50

- Base material / color : Nylon 66 (UL94V-2) / Black
- Nut + screw material / finish : Steel / Trivalent chromate

- Bulk packaging is available. See "Bulk package" column above.
- Screws are not included for bulk packages.

**ASR** series

**ADHESIVE PCB STANDOFF**

**ASR dimensions**

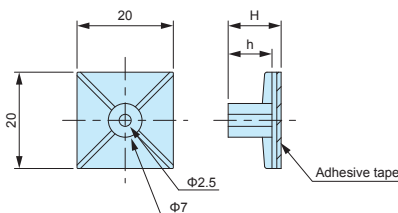

■ DXF/DWG/PDF drawings available on our website.

Technical Data
Recommended torque : 0.4N · m

- M3 tapping screw use adhesive standoff. Recommended to be used with EM-3 or EM-3-6 self-tapping screws (See page 123).
- Please ensure that surface is cleaned and grease-free before adhering.
- Once removed, it cannot be adhered on again.

**Product no. / Dimensions**

Product no	H	h	Weight (g)	Pack of
ASR- 5	5.1	3.1	0.9 (1 piece)	10
ASR- 6	6.4	4.4	1.0 (1 piece)	10
ASR- 7	7.2	5.1	0.9 (1 piece)	10
ASR- 8	8.1	6.3	0.9 (1 piece)	10
ASR- 9	9	7	1.0 (1 piece)	10
ASR-11	11	9	1.0 (1 piece)	10
ASR-13	12.7	10.7	1.2 (1 piece)	10
ASR-14.5	14.7	12.8	1.1 (1 piece)	10
ASR-16	15.9	13.9	1.3 (1 piece)	10
ASR-19	19.1	17.1	1.4 (1 piece)	10