

# LASER CUTTING

Laser cutting utilizes a laser to perform cutting on an object, allowing various types and shapes of holes to be cut.

New fiber laser machine allows the processing of aluminium sheets with both high precision and speed. Processing of Pure Aluminium 1050 is also possible with minimal burr as compared to conventional CO<sup>2</sup> laser machines, which causes excessive burring.



# PUNCHING PRESS

What is punching press? It is a type of machine press used to cut holes in material via the use of various sized die sets.

Punching press allows the realization of high cost performance due to its high speed automated turret punching process, which significantly reduces machining lead-time.

Due to its ability to create designated sized holes by means of rapid multiple hole punches, this enables it to punch holes of various sizes and types quickly and efficiently.

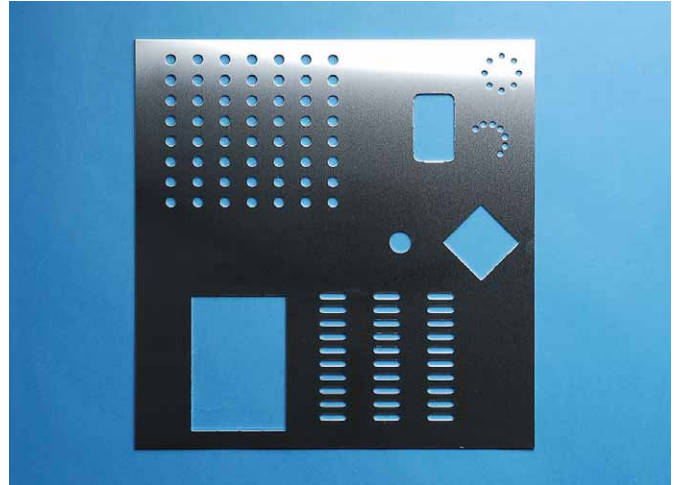
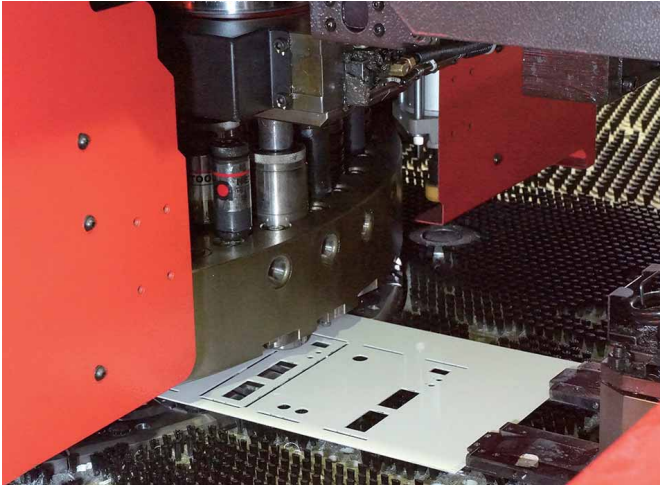

## Circular hole

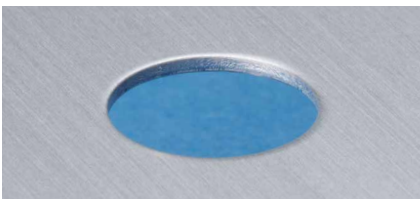

Circular holes as small as 1.0mm in diameter can be punched.

## Nibbling press (rectangle)

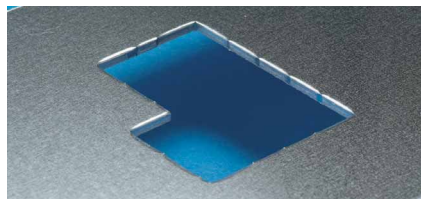

Complex or large rectangular shapes can be punched out with multiple presses.

## Nibbling press (round)

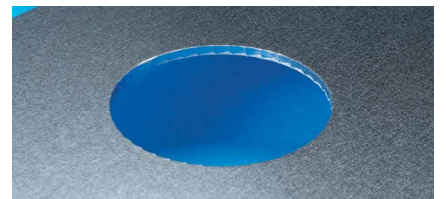

Punching of large circular holes with multiple smaller die strokes.

## Common connector shapes

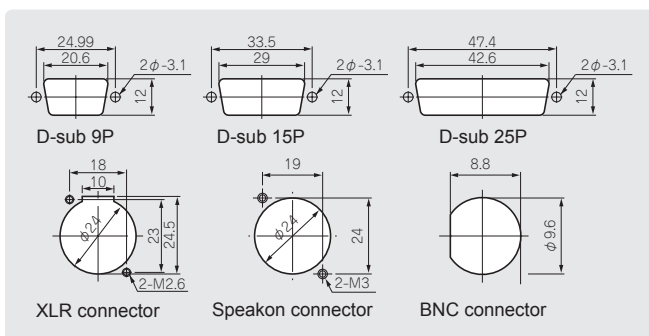

## Unique shapes

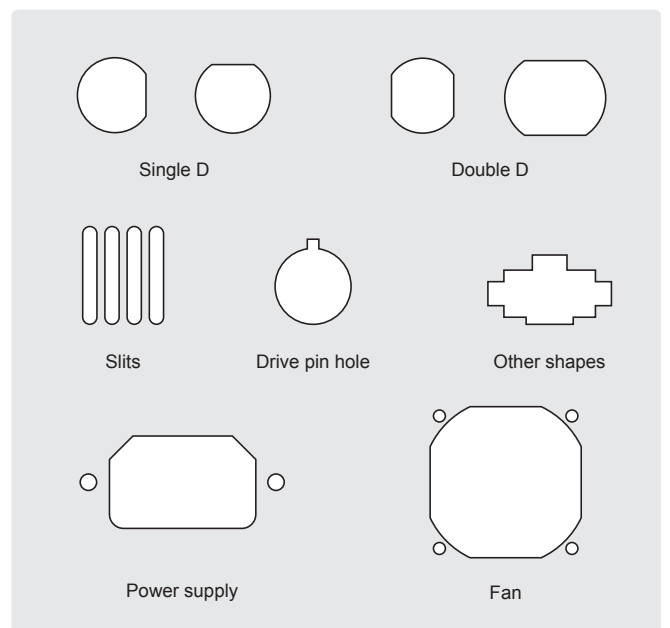

## Burring punch



Increasing surface area on a thin metallic sheet for screw threads to bore into.

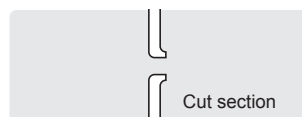

# STANDARD TOLERANCE for MACHINING SERVICES

Our standard tolerance for machining services.

## Hole/Cut Size • Hole/Cut Distance

### Hole/Cut Size (A • B • C)

Dimension	Tolerance
0.5 ~ 3.0	±0.2
3.1 ~ 6.0	±0.2
6.1 ~ 30.0	±0.2
30.1 ~ 120.0	±0.3
120.1 ~ 400.0	±0.5
400.1 ~ 1,000.0	±0.8

### Hole/Cut Distance (D • E)

Dimension	Tolerance
0.5 ~ 3.0	±0.2
3.1 ~ 6.0	±0.2
6.1 ~ 30.0	±0.2
30.1 ~ 120.0	±0.4
120.1 ~ 400.0	±0.6
400.1 ~ 1,000.0	±0.8

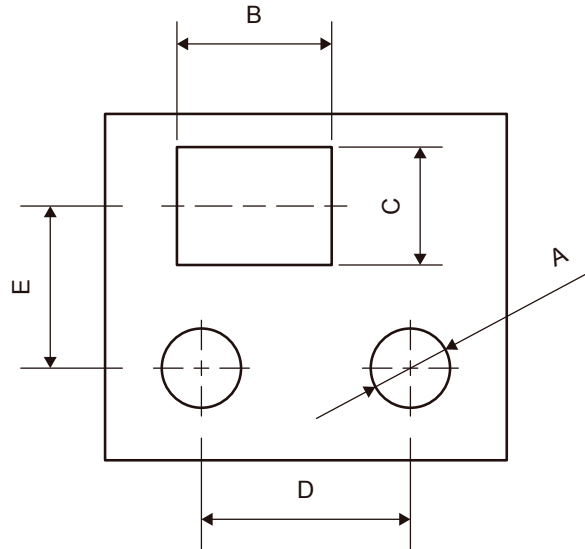

## Distance on Panel - F and G from ORIGIN • H and I from centerline

### Punch Press • Laser Cutting (F • G • H • I)

Dimension	Tolerance
0. ~ 3.0	±0.2
3.1 ~ 6.0	±0.2
6.1 ~ 30.0	±0.2
30.1 ~ 400.0	±0.5
400.1 ~ 1,000.0	±0.6

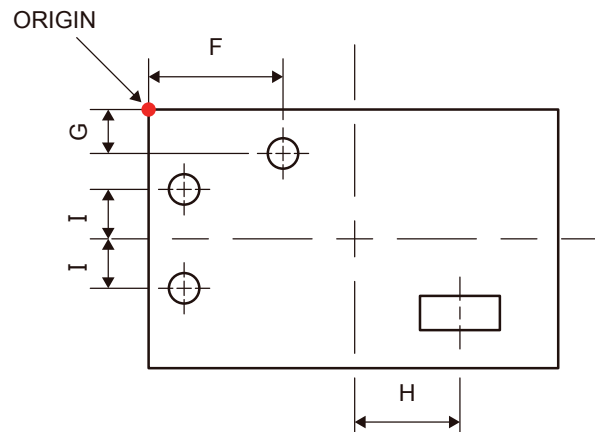

### CNC Machining (F • G)

Dimension	Tolerance
0.5 ~ 3.0	±0.3
3.1 ~ 6.0	±0.3
6.1 ~ 30.0	±0.4
30.1 ~ 120.0	±0.6
120.1 ~ 400.0	±0.8
400.1 ~ 1,000.0	±1.0

### CNC Machining (H • I)

Dimension	Tolerance
0.5 ~ 3.0	±0.5
3.1 ~ 6.0	±0.5
6.1 ~ 30.0	±0.6
30.1 ~ 120.0	±0.8
120.1 ~ 400.0	±1.0
400.1 ~ 1,000.0	±1.2

**Distance on Enclosure - F and G from ORIGIN**

**Material : Extruded Aluminum (F · G)**

Dimension	Tolerance
0.5 ~ 3.0	±0.5
3.1 ~ 6.0	±0.5
6.1 ~ 30.0	±0.6
30.1 ~ 120.0	±0.8
120.1 ~ 400.0	±1.0
400.1 ~ 1,000.0	±1.2

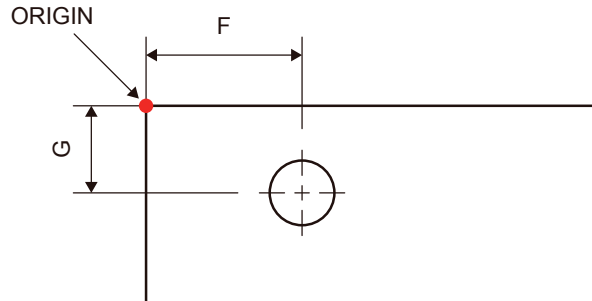

**Material : Aluminum Diecast (F · G)**

Dimension	Tolerance
0.5 ~ 3.0	±1.3
3.1 ~ 6.0	±1.3
6.1 ~ 30.0	±1.4
30.1 ~ 120.0	±1.6
120.1 ~ 400.0	±1.8
400.1 ~ 1,000.0	±2.0

**Material : Plastic (F · G)**

Dimension	Tolerance
0.5 ~ 3.0	±0.5
3.1 ~ 6.0	±0.5
6.1 ~ 30.0	±0.6
30.1 ~ 120.0	±0.8
120.1 ~ 400.0	±1.0
400.1 ~ 1,000.0	±1.2

**Material : Plastic on BCAP, BCPC, BCAR, BCPR and BCPK series (F · G)**

Dimension	Tolerance
0.5 ~ 3.0	±1.1
3.1 ~ 6.0	±1.1
6.1 ~ 30.0	±1.2
30.1 ~ 120.0	±1.4
120.1 ~ 400.0	±1.6
400.1 ~ 1,000.0	±1.8

**Distance on Enclosure - H and I from Centerline**

**Material : Extruded Aluminum (H · I)**

Dimension	Tolerance
0.5 ~ 3.0	±0.8
3.1 ~ 6.0	±0.8
6.1 ~ 30.0	±0.9
30.1 ~ 120.0	±1.1
120.1 ~ 400.0	±1.3
400.1 ~ 1,000.0	±1.5

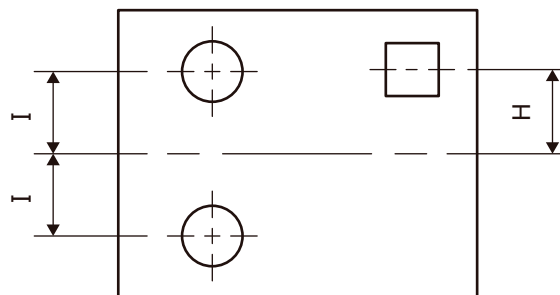

**Material : Aluminum Diecast (H · I)**

Dimension	Tolerance
0.5 ~ 3.0	±2.4
3.1 ~ 6.0	±2.4
6.1 ~ 30.0	±2.5
30.1 ~ 120.0	±2.7
120.1 ~ 400.0	±2.9
400.1 ~ 1,000.0	±3.1

**Material : Plastic (H · I)**

Dimension	Tolerance
0.5 ~ 3.0	±0.9
3.1 ~ 6.0	±0.9
6.1 ~ 30.0	±1.0
30.1 ~ 120.0	±1.2
120.1 ~ 400.0	±1.4
400.1 ~ 1,000.0	±1.6

**Material : Plastic on BCAP, BCPC, BCAR, BCPR and BCPK series (H · I)**

Dimension	Tolerance
0.5 ~ 3.0	±2.1
3.1 ~ 6.0	±2.1
6.1 ~ 30.0	±2.2
30.1 ~ 120.0	±2.3
120.1 ~ 400.0	±2.5
400.1 ~ 1,000.0	±2.8